

SE	Eldningsinstruktion	2
DE	Heizinstruktionen	5
NO	Fyringsinstruksjon	8
DK	Fyringsvejledning	11
IT	Istruzioni per l'accensione	14
FR	Instructions d'allumage	17
NL	Stookinstructies	20
GB	Lighting Instructions	23
FI	Lämmitysohjeet	26

Lighting Instructions



C 600

Contura

Choice of fuel

All types of wood such as birch, beech, oak, elm, ash, softwoods and wood from fruit-trees can be used as fuel in the stove. Different types of wood have different densities. The denser the wood, the greater the energy value. Beech, oak and birch, for example, are all very dense.

Fresh wood comprises 50% water, some of which circulates freely between the fibres, while the remainder is stored in the cells.

Wood should always be allowed to dry so that the freely circulating moisture evaporates. Wood is not suitable for burning until the moisture content has fallen below 20%. Burning wood with a higher moisture content means that a great deal of energy is used to boil away the water. Damp wood also burns poorly, leaving deposits of soot and tar on the lining of the chimney. In severe cases it can even cause chimney fires. In addition it makes the glass on the stove sooty and causes inconvenience to people in neighbouring houses.

To ensure that the wood you use is dry, fell timber in the winter and store it over the summer, well ventilated and under cover. Never cover your wood pile with a tarpaulin that reaches to the ground. This simply seals in the moisture and prevents the wood from drying out.

Keep firewood indoors for a few days before you use it. That way any surface moisture will evaporate.

You can easily check the moisture content of wood by weighing a small sample piece before and after it has been dried in an oven at 80°C for 24 hours. Then calculate the moisture content by dividing the weight of evaporated water by the total initial weight of the piece of wood (in other words, wood + water content).

$$\text{Moisture content \%} = \frac{m \text{ before} - m \text{ after}}{m \text{ before}} \times 100$$

Important. Under no circumstances whatsoever may fossil fuels, pressure impregnated wood, painted or glued wood, chipboard, plastic or colour brochures be used as fuel. When burned, all of these release hydrochloric acid or heavy metals which are hazardous to the environment and damage your stove. Hydrochloric acid can also corrode the steel in the chimney and cause brickwork to crumble and decay.

For good combustion, it is important to ensure that the wood you use is of the correct size:

Kindling wood: fine-split logs

Length: 25 - 33 cm

Diameter: 2 - 5 cm

Amount: 2,5 kg (approx. 8-10 fine-split logs)

Wood: split logs

Length: 25 - 33 cm

Diameter: 7 - 9 cm

Normal amount: 2 kg/hr

Max. amount: 3 kg/hr

Lighting the fire

It is important to use the right amount of wood, especially when first kindling the fire. Before lighting the fire for the first time, weigh the wood on kitchen scales to get an idea of how much 2.5 kg of kindling wood is. Check, too, to see how much the "normal" and "maximum" amounts are.

The stove is designed to be used with the door closed. Always open the door slowly and carefully to prevent the sudden change of pressure in the fire-box from blowing smoke into the room.

A stove reacts in different ways depending on the draught in the chimney. You will normally need to light a fire and use the stove for a few times before you arrive at the optimum setting for the air supply control, the right size for the logs and the correct amount of wood to use.

Starting the fire

Important!

Please note that if too little wood is used when lighting the fire, or if the pieces of wood are too large, it will not be possible to attain the optimum working temperature in the fire-box. This can result in poor combustion and may lead to a heavy build-up of soot, or cause the fire to die out when the door is closed.

If the house has mechanical ventilation and there is negative pressure indoors, open a window near to the stove before lighting a fire. Leave the window open for a few minutes until the fire is blazing. In order to get a glowing bed of embers quickly, make sure there is always a thin layer of ashes and cinders inside the log-guard.

IMPORTANT!

The handle on the left which controls the grate disc should be in the closed position when the fire is burning.

1. Open the air supply control fully.
2. Place screwed-up balls of newspaper or a firelighter in the middle of the fire-box and stack about 2.5 kg of finely split wood on top in a criss-cross pattern.
3. Light the fire.
4. Leave the door slightly ajar for a while, with the lower latch just engaging on the latch-pin. After about 5 or 10 minutes, once the fire is burning well, close the door. (See illustration below.)
5. Before the flames die, stoke the fire with 2 or 3 logs that together weigh 2-3 kg. After about 5 minutes when the logs have caught fire properly, you can reduce the supply of combustion air.

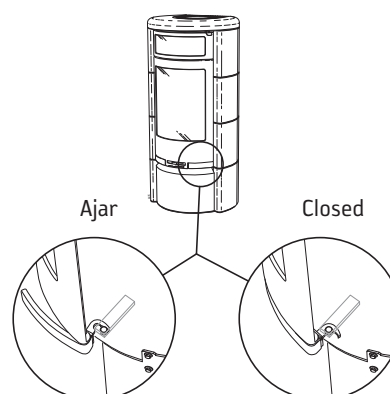

Stoking the fire. Important!

For effective control of the heat output, it is important to have a thick bed of glowing embers and a high temperature in the fire-box.

When the fire has burned down to the embers, it is time to stoke it with more wood.

1. Open the door a fraction and allow the pressure in the fire-box to even out for a few seconds before opening the door fully.
2. Stoke the fire with two or three logs, which together weigh about 2–3 kg. Two of the logs should be laid parallel to the back of the fire-box and the third at an angle on top of them. Alternatively lay just one log parallel to the back of the fire-box and rest the other two on top, roughly at right angles to the first. (See illustration below.) Then close the door.
3. Leave the air supply control in the fully open position for 2–3 minutes until the logs have turned black and are burning well. If you then wish to decrease the rate of combustion, reduce the amount of air supplied to the fire. The conditions for controlling combustion vary depending on the temperature in the fire-box and the draught in the chimney.
4. Under normal conditions a nominal output of 5–6 kW can be obtained when the air supply control is half open.
5. The lowest output of 3–4 kW is normally obtained when the air supply control is 30% open and large logs are being burned. Under these conditions it is important that the air supply control is fully open for about 4–5 minutes so that the wood has a chance to catch fire and burn properly before the supply of air is reduced.

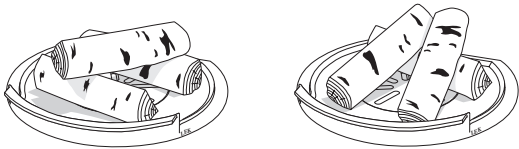

Important!

It is important that the wood starts to burn quickly. To ensure that the logs catch light quickly, open the air supply control fully or leave the door ajar for a short while. Smouldering, i.e. reduced air supply, results in poor combustion and efficiency with high emission discharges and can, in worst-case scenarios, cause rapid gas ignition resulting in stove damage.

General information

Fires should not be too large. Big fires are uneconomical. They also produce too much heat and can actually damage the stove and chimney. Under normal conditions the recommended rate of wood consumption is 2 kg per hour. When burning chopped birch or other deciduous woods with a moisture content of approx. 18%, the maximum permissible amount is 3 kg per hour. Burning the same amounts of coniferous wood will result in much higher temperatures in the fire-box. Burning the maximum amounts of wood for long periods will shorten the life of a woodstove. Burning amounts of wood in excess of those given above can damage components inside the stove and will invalidate the guarantee.

When the stove is new

Oily coatings on the metal, and paint left on the metal components may produce a distinctive smell when the stove is new. This smell will disappear once the woodstove has been used a few times.

You may also notice an acrid smell after using the stove for a while. This comes from the insulation in the chimney and can be remedied by burning the maximum amount of wood (3 kg/hour) for a period of 5–8 hours.

Stove maintenance

The glass on the doors can accumulate soot even when the stove is fuelled with dry wood with a moisture content of 15–20%. If you clean it regularly, it is often enough simply to wipe the glass with dry paper. Accumulations of soot on the glass doors are best removed with a cleaning liquid or with any of the proprietary sootremovers available from larger stores or your stove supplier.

- Never use abrasive cleaners, as these may damage the glass.
- Ensure that no embers remain when removing ash from the stove. The ash must be stored in a fireproof container with a lid for at least a week before being disposed of.
- Also clean inside the area where the ash-pan is located, otherwise spilled ash can prevent the ash-pan from being fully inserted and prevent the fireplace door from being closed properly.
- Clean the soapstone with detergent or wipe it with a clean cloth and pure acetone. Do not put candles or anything inflammable on the soapstone.
- The grate needs cleaning several times per season. The grate and other cast-iron parts may be cleaned with a steel brush.
- It is important to check washers and seals now and again. If they become worn, air seeping into the fire-box may affect the performance of the stove.
- Lacquered parts may be cleaned with a damp cloth, and a little washing-up liquid if necessary. Damage to lacquered parts, such as small scratches, may be repaired with Contura touch-up paint. Please contact your supplier.
- There is a constant flow of air through the stove: cold air is drawn in from the room and hot air expelled, so dust can gather behind and beneath the stove. These areas require regular cleaning.
- Parts that are close to the seat of the fire may need replacing. Examples are the baffle, fire-bricks and grate. How long these parts last depends on the amount and type of use the stove has had.

Soot removal

Removal of soot from flues and chimneys should be carried out by a qualified chimney sweep. Soot may be removed from the stove itself by scraping or brushing the sides of the fire-box, although a soot vacuum cleaner is more effective. If deposits of soot catch fire or if there is a risk that they will do so, close the air intake control and shut the door. If necessary, contact the fire brigade to put out the fire. After a soot or chimney fire, the chimney should always be inspected by a chimney sweep.

Possible causes of operating problems and remedies

Poor draught in the stove after installation.

- Check the length of the chimney so that it meets NIBE's recommendations, that is a total length of at least 3.5 metres.
- Check that there is no blockage in the chimney that prevents smoke and fumes from escaping, and that there is no house or tree nearby that is affecting the wind around the chimney.
- Check the cross-sectional area of the chimney (existing brick chimneys only) which should be 150–200 cm².

The fire is difficult to light and dies after a short while.

- This may be because the wood is too damp. Check your wood.
- Another reason may be that there is negative pressure in the house, for example when using a kitchen extractor fan or other mechanical ventilation. Open a window near to the stove when you light it. You can try lighting some newspapers and holding them up inside the stove to get the draught going.
- The air supply conduit from the outside may be completely or partially blocked. Disconnect the supply of air from outside, and try to light the fire using only the air in the room.
- Check that the air supply control is open.
- The smoke outlet/chimney damper may be blocked by soot. This sometimes occurs after sweeping. Remove the smoke baffle and check
- Finally go through the lighting instructions again. If the amount of wood you have used is too small, the glowing embers may be too few and too cool to provide enough heat to light the next batch of wood.

Abnormally large soot deposits on the glass.

A certain amount of soot will always accumulate on the glass. These soot deposits will increase each time the fire is used. Soot on the glass is usually caused by three things:

- Damp wood, which causes poor combustion with a large amount of smoke as a result.
- Too low a temperature in the fire-box. This results in an excessive amount of smoke and a poor draught in the chimney.
- Failure to carry out procedures correctly: for example, not leaving the door ajar for approx. 5 minutes.

Check that the wood is dry. Make sure that there is a good bed of glowing embers and study the lighting instructions once again.

Smell of smoke near the stove at certain times.

This can occur when the wind blows down the chimney. More often than not, this happens only when the wind is blowing from a certain direction. Another reason for this may be if the door is left open when the fire is burning fiercely.

Lacquered components become discoloured.

If lacquered components become discoloured, the temperature in the stove is too high. This may be because the fire-box has been stoked with too much wood or with unsuitable wood (building waste, excessive quantities of finely chopped wood etc.). The manufacturer's guarantee does not cover damage caused by using the wrong wood. Lacquered components that have been damaged can, however, easily be replaced. Contact your stove supplier, who will be pleased to assist.

If problems arise that you cannot rectify yourself, please contact your stove supplier or chimney sweep.

We hope that the hints and tips in this brochure will help you to get the very best use, enjoyment and economy out of your Contura stove.

Warning!

When the stove is in use certain surfaces become very hot. Physical contact with these surfaces can cause skin burns. Pay particular attention also to the high temperatures of the heat radiated through the glass door. Do not place combustible material closer than the recommended safe distances. Failure to observe these safe distances can result in an uncontrolled fire.

A smouldering fire can cause gases and fumes to ignite without warning, with the risk of causing damage to both persons and property.