

Contura

C310

C310G

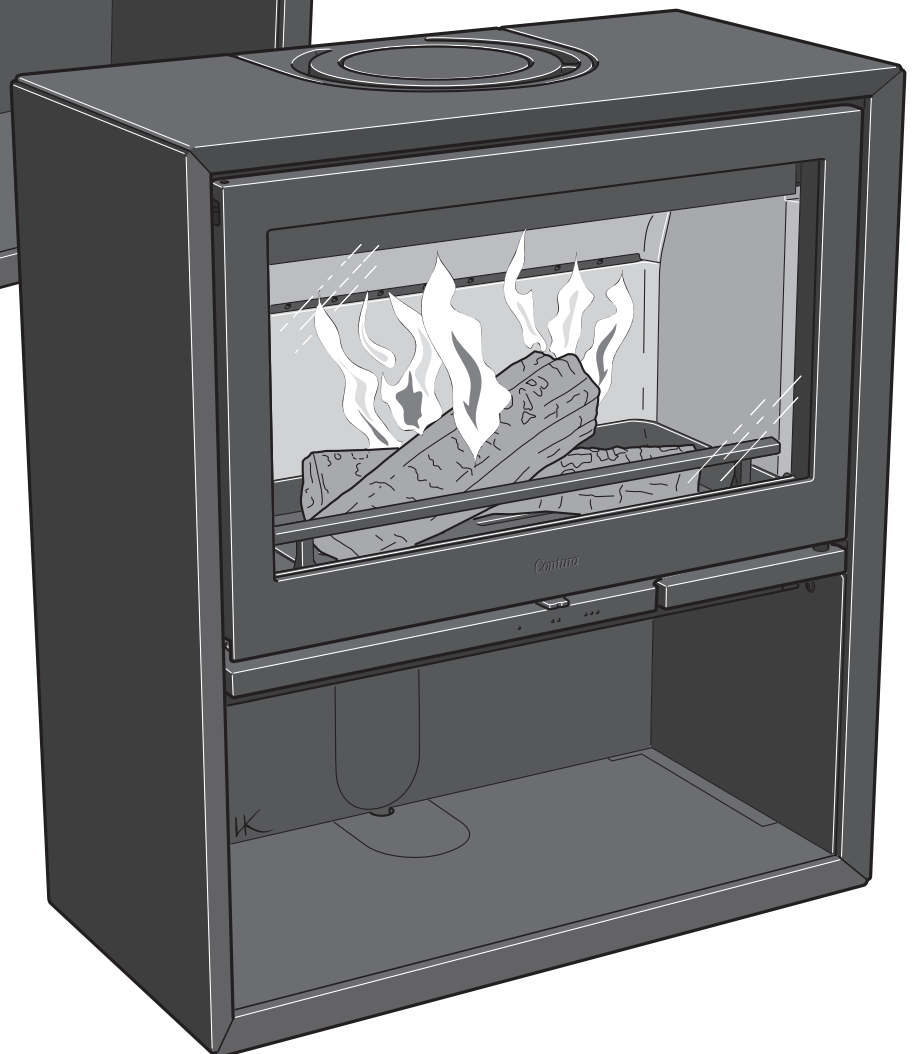

SE

Fakta	3
Installationsavstånd	4
Prestandadeklaration	5
Montering	30

DE

Fakten	6
Installationsabstände	7
Leistungsdeklaration	8
Montage	30

NO

Fakta	9
Installasjonsavstand	10
Ytelseserklæring	11
Montering	30

FR

Données Techniques	12
Distances d'installation	13
Déclaration des performance	14
Montage	30

GB

Facts	15
Installation distances	16
Declaration of performance	17
Assembly	30

DK

Fakta	18
Installationsafstand	19
Præstationserklæring	20
Montering	30

FI

Tiedot	21
Asennusetäisyys	22
Suoritusosoilmoitus	23
Asennus	30

IT

Dati Tecnici	24
Distanze di sicurezza	25
Dichiarazione di prestazione	26
Montaggio	30

NL

Gegevens	27
Installatieafstand	28
Prestatieverklaring	29
Monteren	30

Facts



5-9 kW



850 mm



750 mm



375 mm



130 kg

Nominal effect
Efficiency

7 kW
77%

Meets requirements of:
European standard EN-13240
NS 3058/3059 (Norway)
DEFRA, Smoke control areas (UK)

Installation by authorised technician

This manual contains instructions about how the stoves must be assembled and installed. To ensure the function and safety of the stove, we recommend that the installation is carried out by an authorised technician. Contact one of our dealers who can recommend suitable technicians.

Structural support

Check that the wood joists are strong enough to bear the weight of the stove and chimney. The stove and chimney can usually be placed on a normal wooden joist in a single occupancy house if the total weight does not exceed 400 kg.

Hearth plate

Due to the risk of falling embers, a flammable floor must be protected by a hearth plate. It must extend 300 mm in front of the stove and 100 mm on each side of the stove, or have a 200 mm extension on each side of the opening. The hearth plate can consist of natural stone, concrete, metal plate or glass. A glass hearth plate is available as an accessory for these models.

Final inspection of the installation

It is extremely important that the installation is inspected by an authorised chimney sweep before the stove is used. Also read the "Lighting instructions", before lighting for the first time.



The stove becomes very hot

During operation, certain surfaces of the stove become very hot and can cause burn injury if touched. Be aware of the strong heat radiated through the hatch glass. Placing flammable material closer than the safe distance indicated may cause a fire. Pyre lighting can cause quick gas ignition with the risk of damage to property and personal injury.

Building application

These main instructions may give guidance which would contravene national building regulations. Please refer to supplementary instructions or ask your local authority for advice regarding building regulations. Before installing a stove or erecting a chimney it is necessary for you to make a building application permission to your local authority. The owner of the house is personally responsible for ensuring compliance with the mandatory safety requirements and must have the installation approved by a qualified inspector. Your local chimney sweep must also be informed about the installation as this will affect the routines for regular chimney-sweeping services.

Connection to chimney

- The stove must be connected to chimneys dimensioned for a minimum flue gas temperature of 400°C.
- The external diameter of the connection sleeve is 150 mm.
- Normal chimney draw under nominal operation should be between 20-25 Pa close to the connector. The draft is affected both by the length and area of the chimney, and by how well sealed it is. Minimum recommended chimney length is 3.5 m and suitable cross section area is 150-200 cm² (140-160 mm in diameter).
- A flue with sharp bends and horizontal routing reduces the draught in the chimney. Maximum horizontal flue is 1 m, on the condition that the vertical flue length is at least 5 m.
- It must be possible to sweep the full length of the flue and the soot hatches must be easily accessible.
- Carefully check that the chimney is sealed and that there is no leakage around soot hatches and flue connections. See page 31.

Supply of combustion air

When a stove is installed in a room, the demand for air supply to the room increases. Air can be provided indirectly via a vent in the outer wall or via a duct from the outside that is connected to the connector on the underneath of the stove. The amount of air needed for combustion is 20 m³/h.

The connector for the combustion air has an external diameter of 65 mm. When duct routing further than 1 m the pipe diameter must be increased to 100 mm and a correspondingly larger wall vent must be selected.

In hot areas, the duct should be insulated with 30 mm mineral wool with a moisture inhibiting outer cover. It is also important to seal around the hole in the wall (or floor) of the lead-in using sealant.

A 1 m length of condensation insulated ducting for combustion air is available as an accessory. See page 33.

Installation distances

C310

The minimum distance in front of the stove opening to combustible parts of the building or interior decoration must be at least 1,4 m.

The dimension diagrams only show the minimum permitted installation distances for the stove. When connecting to a steel flue, also note the safety distance requirements of the flue. The safety distance between an un-insulated flue and a combustible part of the building should be at least 450 mm.

- A = height from floor to chimney connection upwards
- B = height from floor to c/c chimney connection rear
- C = height from floor to air inlet
- D = height from floor to lower edge of hatch
- E = height from floor to lower edge of heat deflector

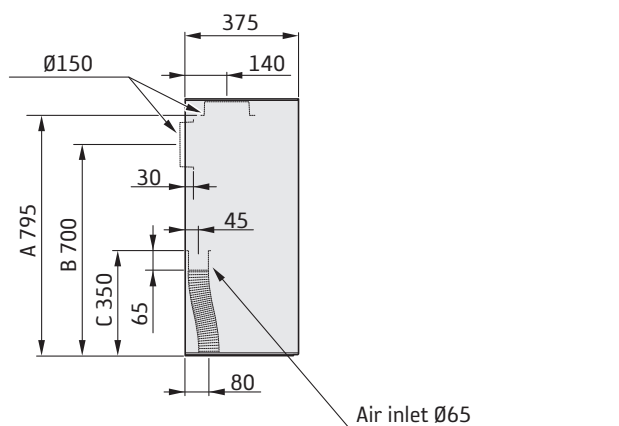
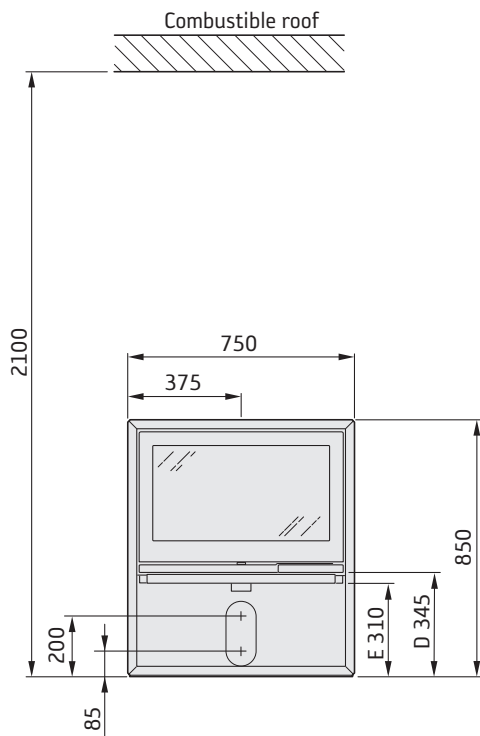

INSTALLATION AGAINST COMBUSTIBLE WALLS

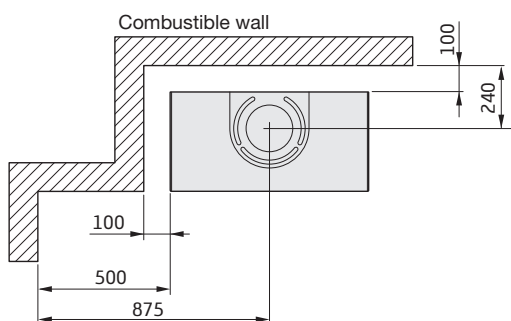

INSTALLATION AGAINST FIREWALLS

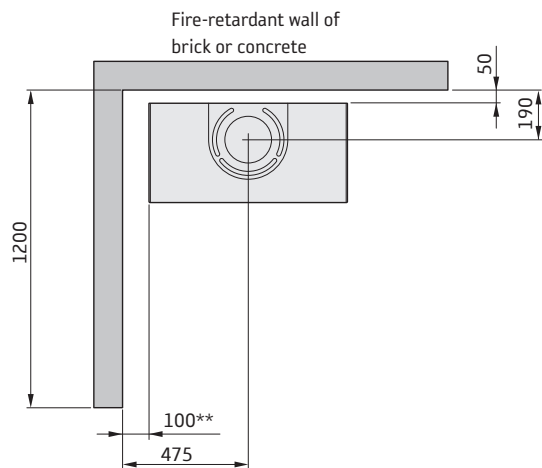

* If the stove is placed on a hearth plate made of glass for example (accessory), the height from the floor is affected by a distance corresponding to the thickness of the hearth plate, for a free standing glass hearth plate this is 10 mm.

** To prevent discolouration of painted non-flammable walls we recommend that the same side distance as to combustible walls is used.

Declaration of performance according
to Regulation (EU) 305/2011
No. C310/C310G-CPR-170824

Contura

PRODUCT

Product type Stove lit with solid biofuels
Type designation Contura 310 / 310G
Manufacturing number See rating plate on the stove
Intended area of use Heating of rooms in residential buildings
Fuel Wood

MANUFACTURER

Name NIBE AB / Contura
Address Box 134, Skulptörvägen 10
SE-285 23 Markaryd, Sweden

CHECKS

According to AVCP System 3
European standard EN 13240:2001/A2:2004/AC:2007
Test institute Rein-Ruhr Feuerstätten Prüfstelle, NB 1625,
has checked declared performance and issued test report no. RRF-40 17 4648

DECLARED PERFORMANCE

Essential characteristics	Performance	Harmonised technical specification
Reaction to fire	NPD	EN 13240:2001/A2:2004/AC:2007
Minimum distance to combustible material	Rear: 100 mm Side: 500 mm Other safety distances according to the installation instructions	
Risk of falling embers	Pass	
Emissions from combustion	CO 0,07 %	
Surface temperatures	Pass	
Cleaning options	Pass	
Mechanical durability	Pass	
Emissions of hazardous substances	Pass	
Nominal output	7 kW	
Efficiency	77 %	
Flue gas temperature in connector at nominal output	369°C	

The undersigned is responsible for the manufacture and conformity with the declared performance.



Niklas Gunnarsson, Business area manager NIBE STOVES
Markaryd, 1st September 2017



SE Montering

Om kaminen behöver läggas ned för att förflyttas bör lösa delar demonteras. Demontering av eldstadsbeklädnad beskrivs i slutet av denna anvisning.

- 1 Eldstadsbeklädnad (Vermiculit)
- 2 Typskylt
- 3 Bräsbegränsare
- 4 Roster
- 5 Inre bottenplåt
- 6 Varmluftsgaller

FR Avant de procéder au montage

Les éléments non fixés devront être retirés si le poêle doit être couché pour être déplacé. Le démontage de l'habillage est décrit à la fin des présentes instructions.

- 1 Habillage du foyer (Vermiculite)
- 2 Plaque signalétique
- 3 Grille de retenue
- 4 Grille
- 5 Plaque de fond intérieure
- 6 Grille air chaud

FI Ennen asennusta

Jos takka pitää siirtää kyljellään, irto-osat pitää irrottaa. Palotilaverhouksen irrotus kuvataan ohjeen lopussa.

- 1 Tulipesän verhouk (vermikuliitti)
- 2 Tyypikilpi
- 3 Suojareunus
- 4 Arina
- 5 Sisempi pohjapelti
- 6 Lämminilmaritilä

DE Vor der Montage

Wenn der Kaminofen in liegender Position versetzt werden muss, sind lose Komponenten zu demontieren. Demontage und Brennraumauskleidung werden am Ende dieser Anleitung beschrieben.

- 1 Feuerstättenauskleidung (Vermiculit)
- 2 Typenschild
- 3 Stehrost
- 4 Rost
- 5 Innere Bodenplatte
- 6 Warmluftgitter

GB Prior to installation

If the stove needs to be laid down for it to be moved, loose components should be removed. A description of how to remove hearth cladding can be found at the end of these instructions.

- 1 Fire bricks (Vermiculite)
- 2 Type plate
- 3 Fire bars
- 4 Grate
- 5 Inner bottom panel
- 6 Hot air grille

NO Før montering

Hvis ovnen må legges ned for å flyttes, bør løse deler demonteres. Demontering av ildstedsbekledning er beskrevet til slutt i denne veiledningen.

- 1 Brennplater og hvelv (Vermikulitt)
- 2 Typeskilt
- 3 Kubbestopper
- 4 Rist
- 5 Innvendig bunnplate
- 6 Varmluftsgitter

DK Før opstilling

Hvis brændeovnen skal lægges ned for at blive flyttet, bør løsdele afmonteres. Afmontering af ovnbekledning beskrives i slutningen af denne vejledning.

- 1 Ovnbeclædning (Vermiculite)
- 2 Typeskilt
- 3 Brændeholder
- 4 Rist
- 5 Indre bundplade
- 6 Varmluftsgitter

IT Prima del montaggio

Se è necessario smontare l'inserto per spostarlo, rimuovere prima i componenti liberi. L'operazione di smontaggio è descritta alla fine delle presenti istruzioni.

- 1 Rivestimento interno del focolare (vermiculite)
- 2 Targhetta identificativa
- 3 Griglia ferma-legna
- 4 Griglia
- 5 Piastra di fondo interna
- 6 Griglia di ventilazione

NL Voorafgaand aan montage

Als de kachel liggend moet worden verplaatst, moeten losse onderdelen worden gedemonteerd. Aan het eind van deze instructies vindt u een beschrijving van de demontage van de haardbekleding.

- 1 Haardbekleding (vermiculiet)
- 2 Typeplaatje
- 3 Houtvanger
- 4 Rooster
- 5 Bodemplaats binnenzijde
- 6 Heteluchtrooster

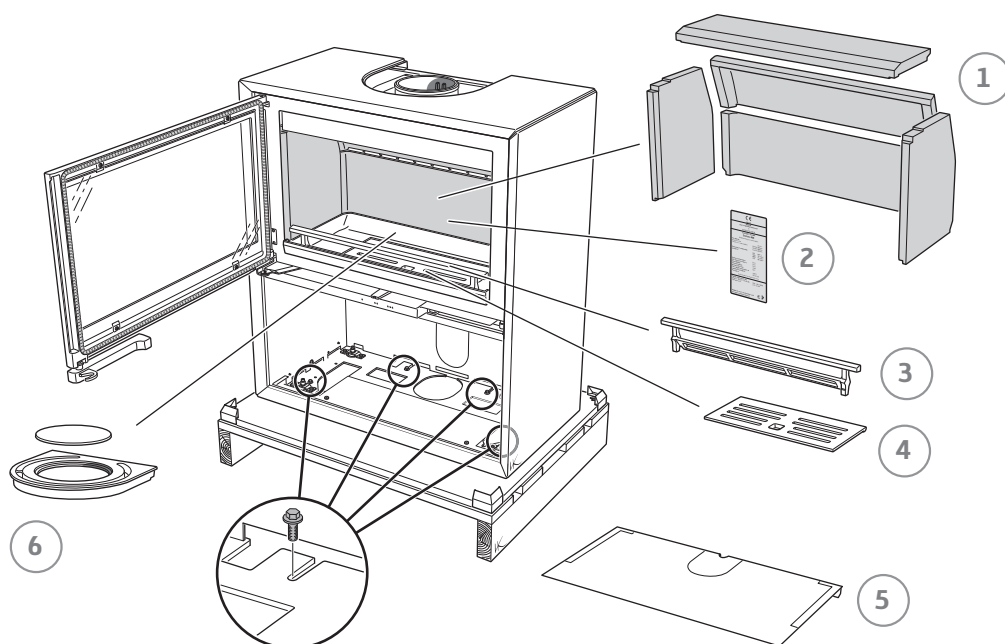



- SE Bakåtanslutning till murad skorsten
- DE Rückseitiger Anschluss an einen gemauerten Schornstein
- NO Bakmontering til murt skorstein
- FR Raccordement par l'arrière à une cheminée de maçonnerie
- GB Rear connection to a masonry chimney
- DK Tilslutning bagud til muret skorsten
- FI Liitäntä taaksepäin muurattuun savupiippuun
- IT Collegamento alla canna fumaria in muratura dal retro della stufa
- NL Achterwaartse aansluiting op een gemetselde schoorsteen

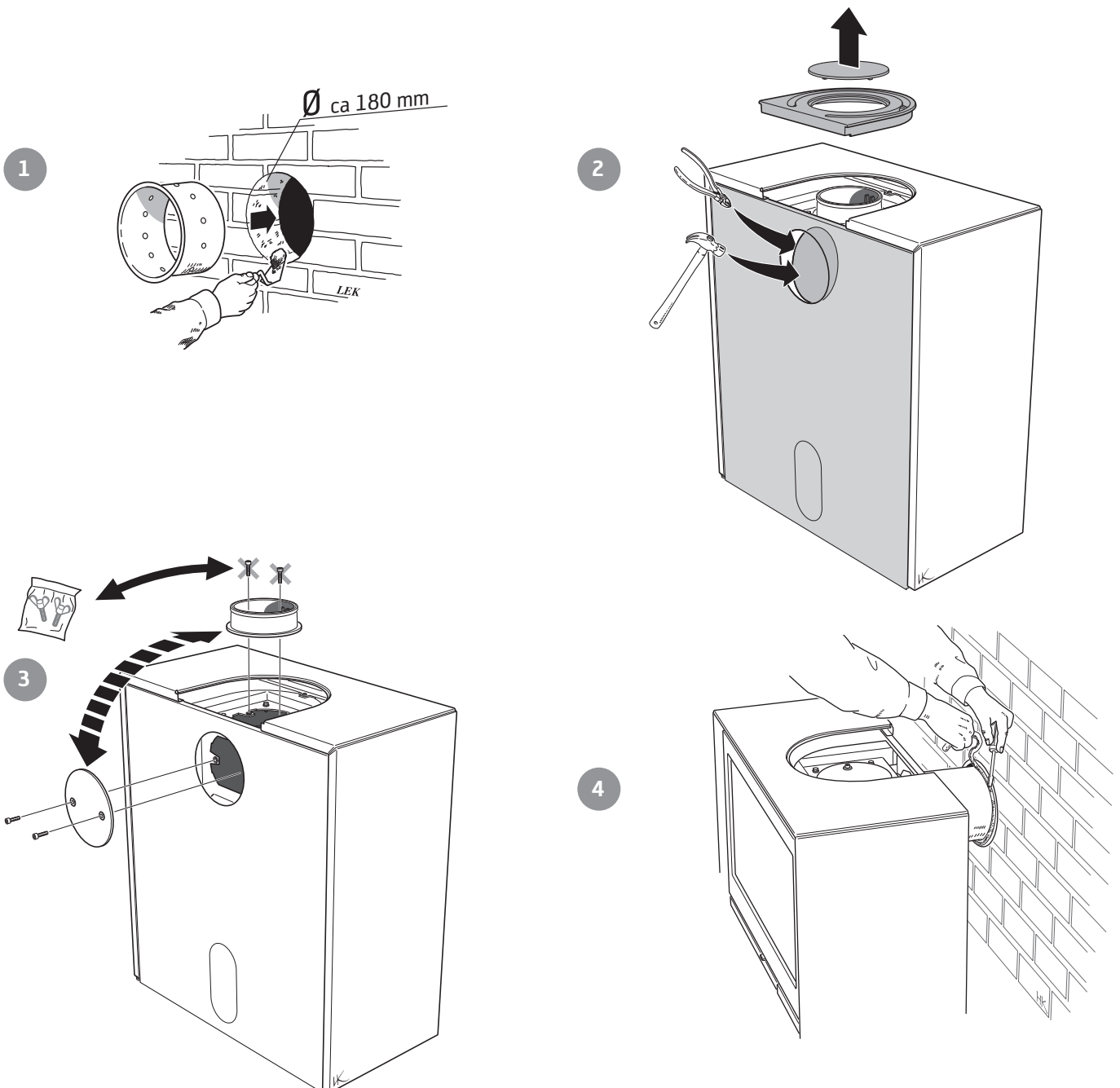

- SE** Toppanslutning till skorsten
Varmluftsgallret måste vara monterat innan skorstenen toppansluts.
- DE** Oberseitiger Anschluss an den Schornstein
Das Warmluftgitter muss montiert sein, bevor ein Schornsteinanschluss an der Oberseite erfolgt.
- NO** Toppmontering til skorstein
Varmluftsgitteret må være montert før skorsteinen topptilkobles.
- FR** Raccordement par le haut
Monter la grille d'air chaud avant le raccordement à la cheminée par le haut.
- GB** Top connection to the chimney
The hot air grille must be installed before chimney top connection.
- DK** Toptilslutning til skorsten
Varmluftstrøsten skal være monteret, før skorstenen toptilsluttes.
- FI** Liitääntä ylöspäin savupiippuun
Lämminilmaritilä pitää asentaa ennen savupiipun liitääntä ylöspäin.
- IT** Collegamento alla canna fumaria dal piano della stufa
Prima di collegare la canna fumaria al piano della stufa, assicurarsi che la griglia dell'aria calda sia montata.
- NL** Bovenansluiting op een schoorsteen
Het heteluchtrooster moet zijn gemonteerd, voordat de schoorsteen op de bovenansluiting wordt aangesloten.

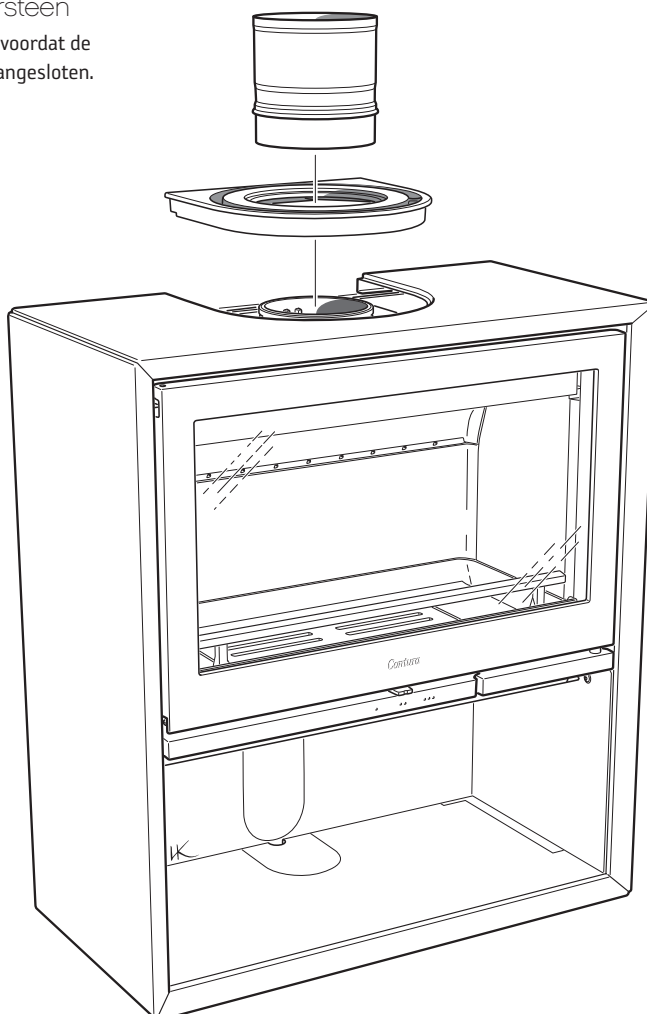



- SE Tilluft
- DE Zuluft
- NO Tilluft
- FR Arrivée d'air
- GB Supply
- DK Forbrændingsluft
- FI Tuloilma
- IT Alimentazione dell'aria
- NL Toevoerlucht

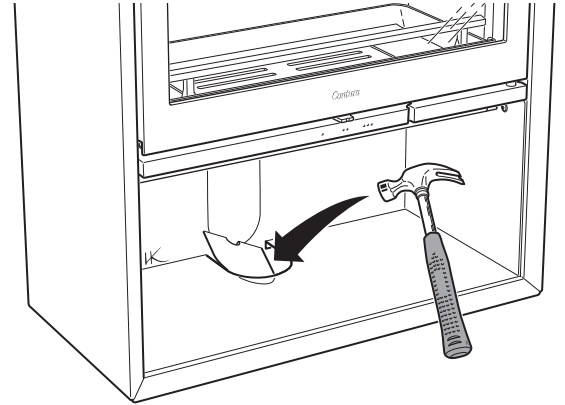
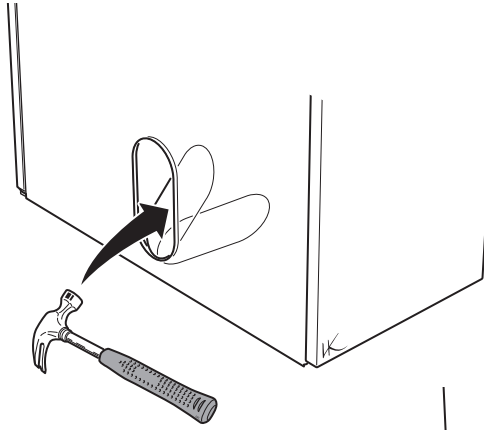

1

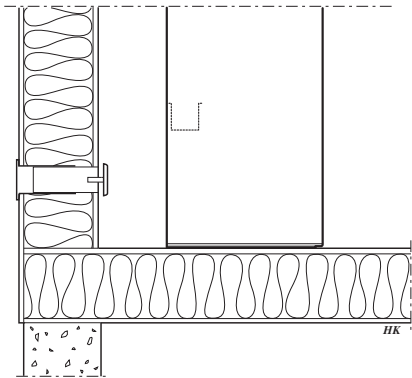

2

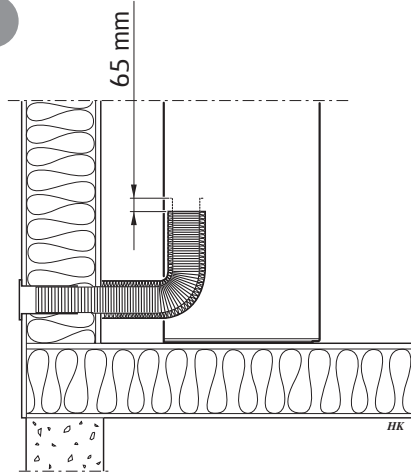

3

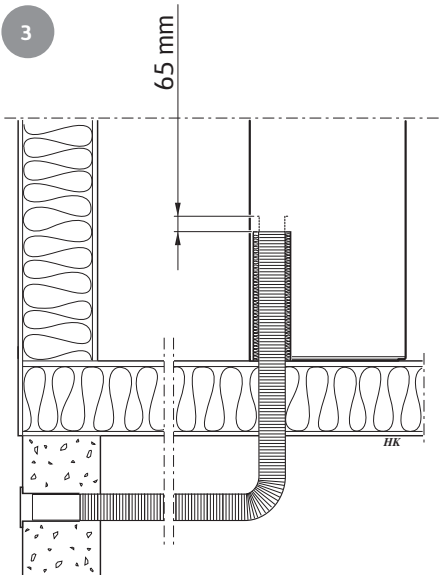

4

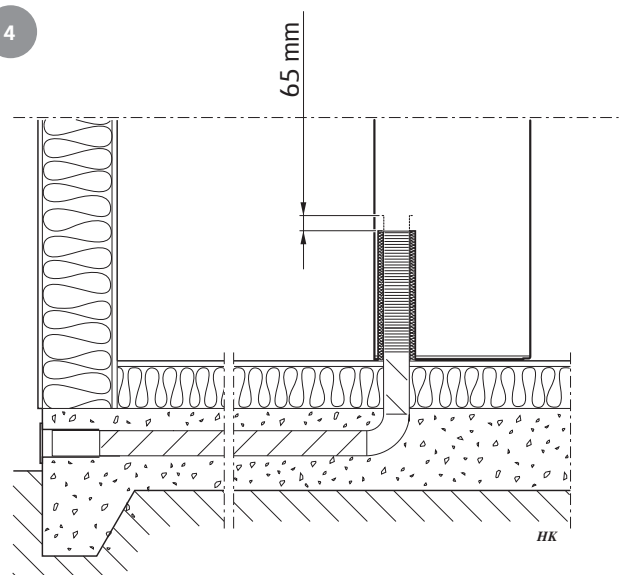

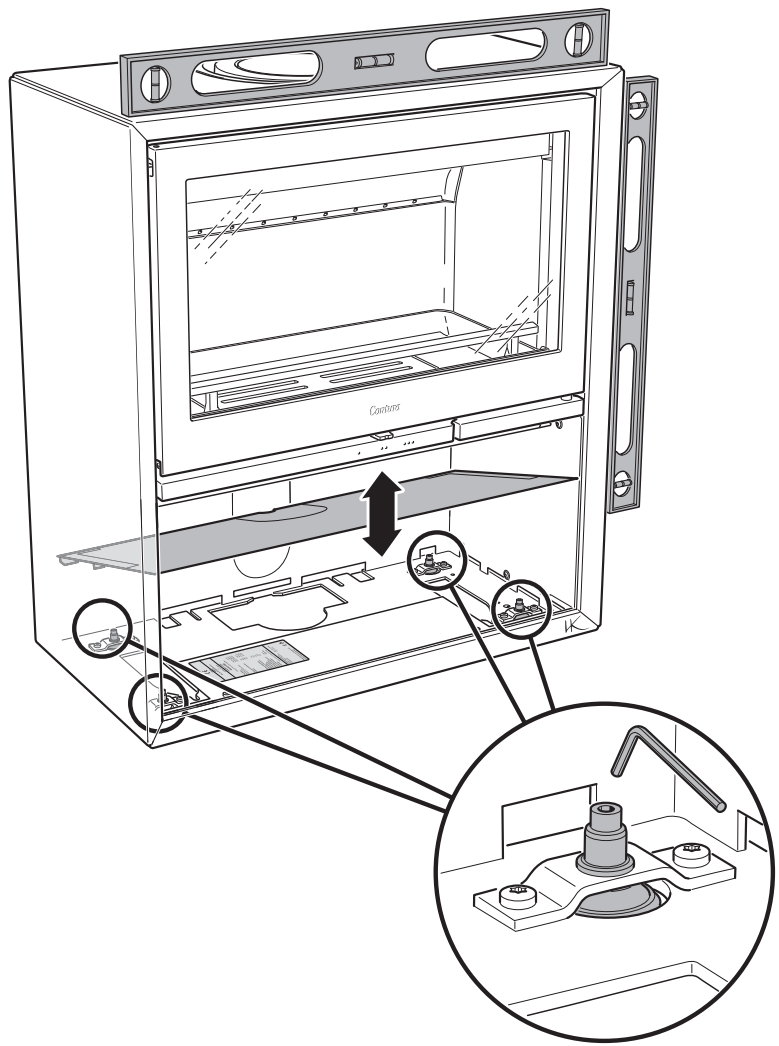
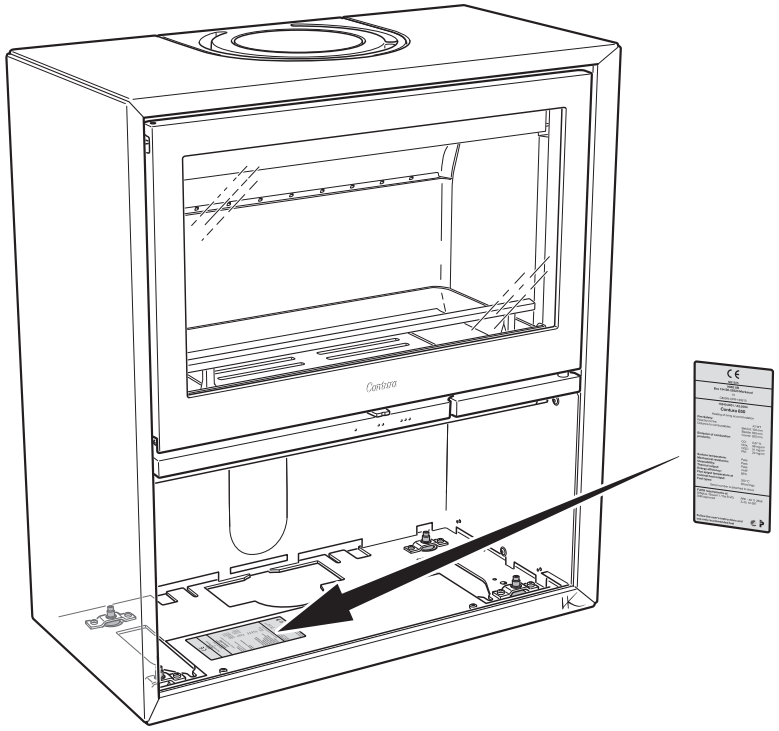



- SE** Uppställning av luckan
Luckan kan spärras i öppet läge, med hjälp av tryckknappen på kaminens undersida.
- DK** Spærring af lågen
Lågen kan spærres i åben position ved hjælp af trykknappen under brændeovnen.
- DE** Aufstellung der Tür
Mithilfe der Taste an der Kaminofenunterseite kann die Tür in ihrer geöffneten Stellung arretiert werden.
- FI** Luukun asennus
Luukku voidaan lukita avattuun asentoon takan alapuolella olevalla painonapilla.
- NO** Låsing av døren i åpen posisjon
Døren kan låses i åpen posisjon ved hjelp av knappen på undersiden av ovnen.
- IT** Bloccaggio dello sportello
Lo sportello può essere bloccato in posizione aperta con un pulsante posto sotto la camera di combustione.
- FR** Mise en place de la porte
La porte peut être verrouillée en position ouverte, à l'aide du bouton-poussoir sur le dessous du poêle.
- NL** Plaatsen van het luik
Het luik kan in geopende stand worden vergrendeld met behulp van de drukknop aan de onderkant van de kachel.
- GB** Installation of the door
The door can be held in the open position using the push button on the underside of the stove.

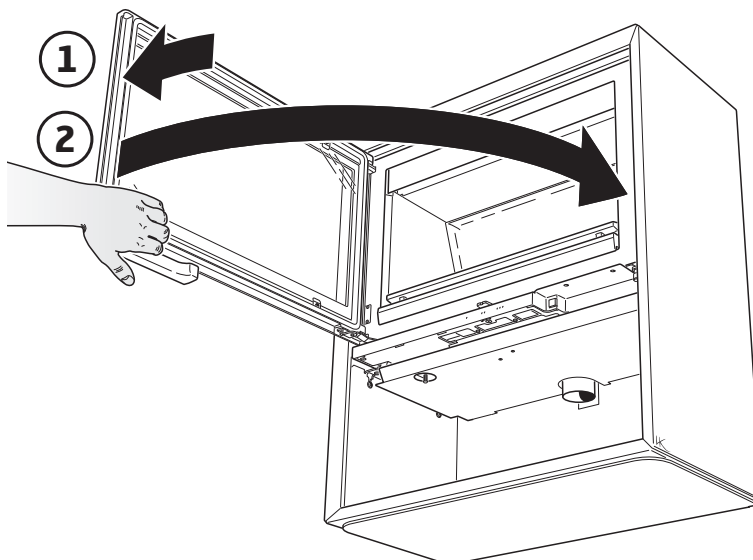
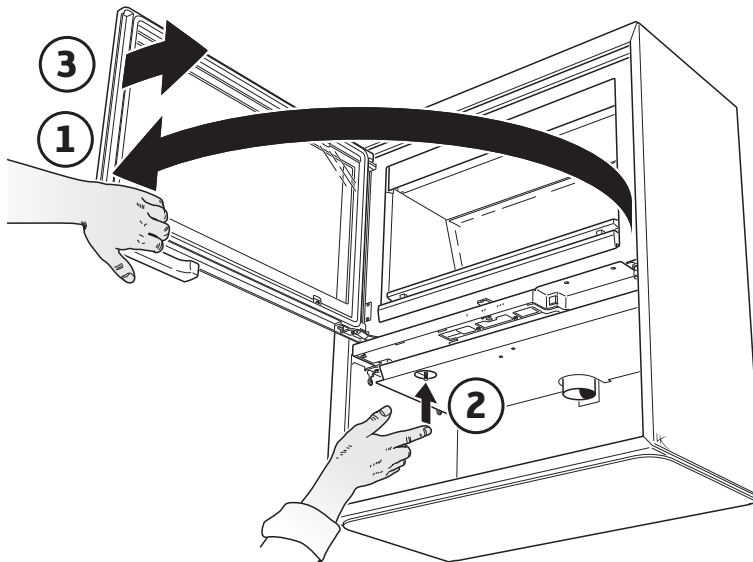



- SE Demontera eldstadsbeklädnaden (Vermiculit)
- DE So demontieren Sie die Brennraumauskleidung (Vermiculit)
- NO Slik demonterer du ildstedsbekledningen (Vermikulitt)
- FR Voici comment démonter l'habillage du foyer (Vermiculite)
- GB How to remove the hearth surround (Vermiculite)
- DK Sådan afmonterer du ovnbeklædningen (Vermiculite)
- FI Näin irrotat tulipesän verhouksen (vermikuliitti)
- IT Come smontare il rivestimento del focolare (vermiculite)
- NL Zo demonteert u de kachelbekleding (vermiculiet)

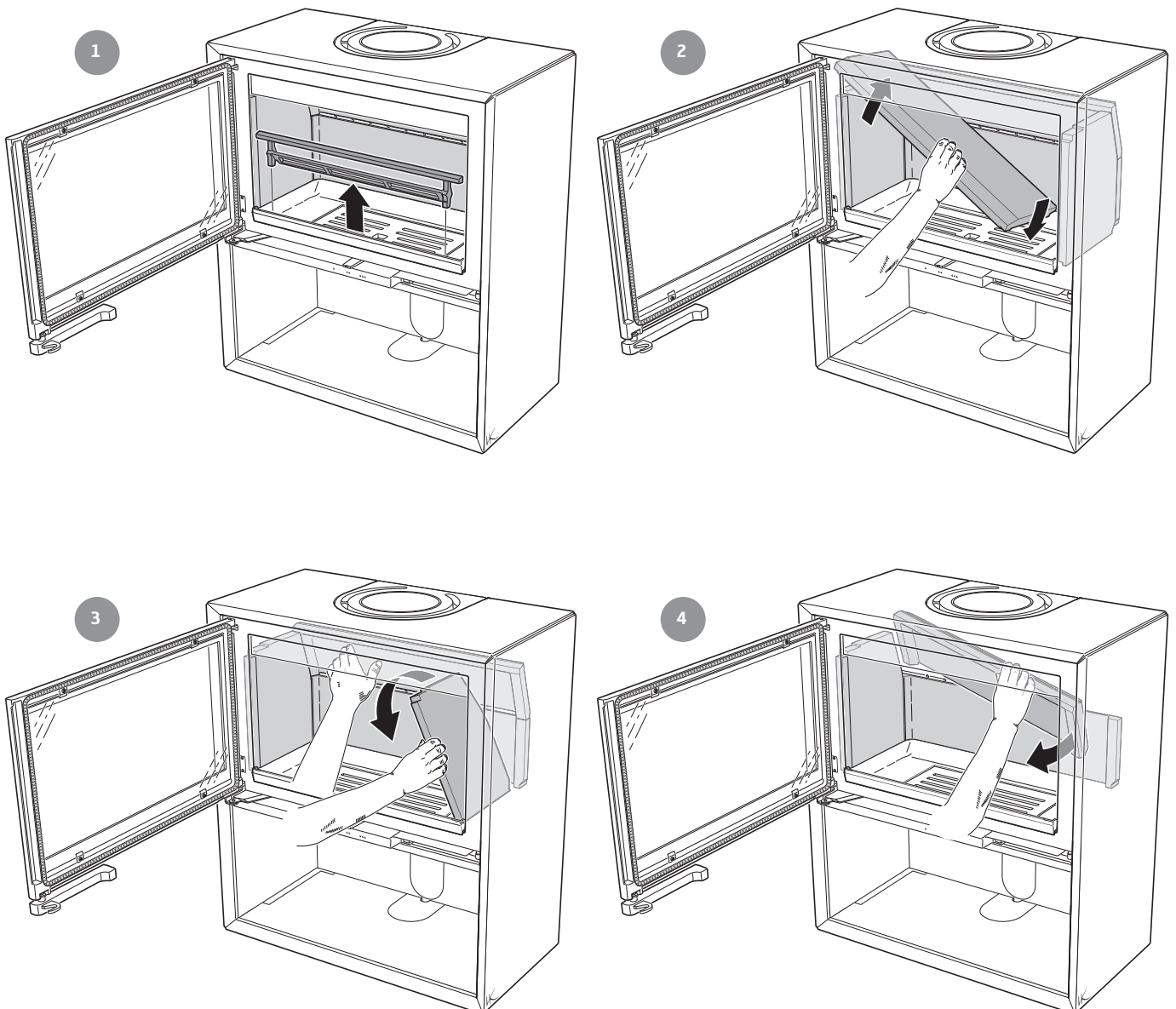

5

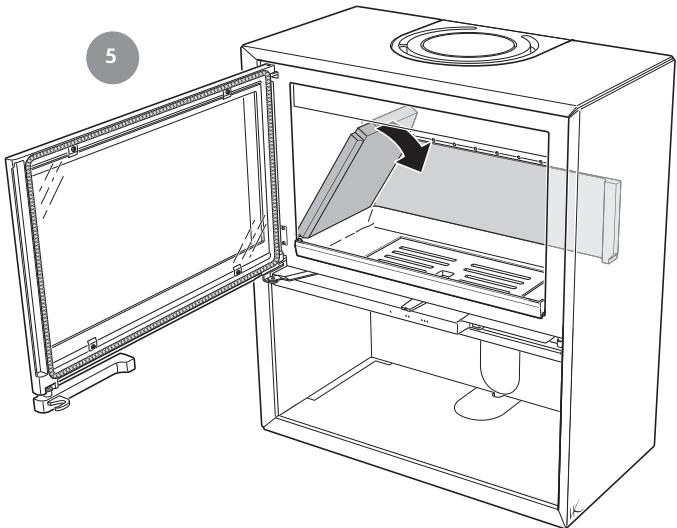

6

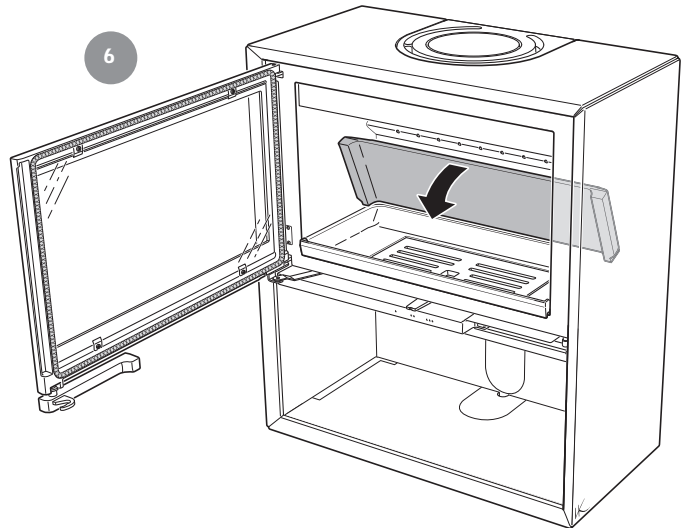

7

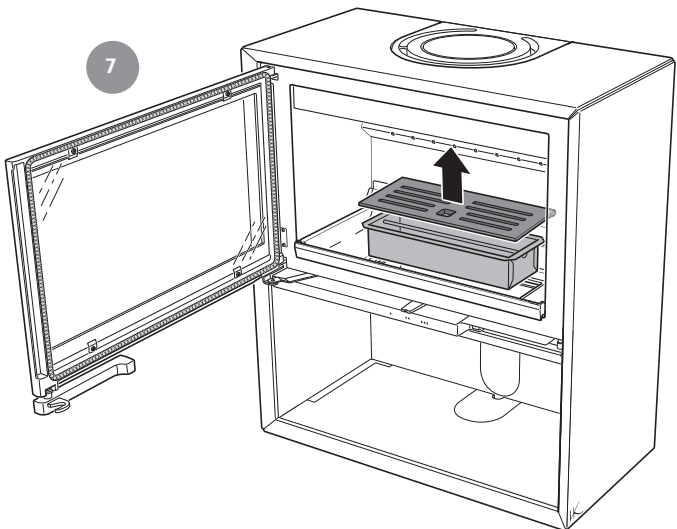

8

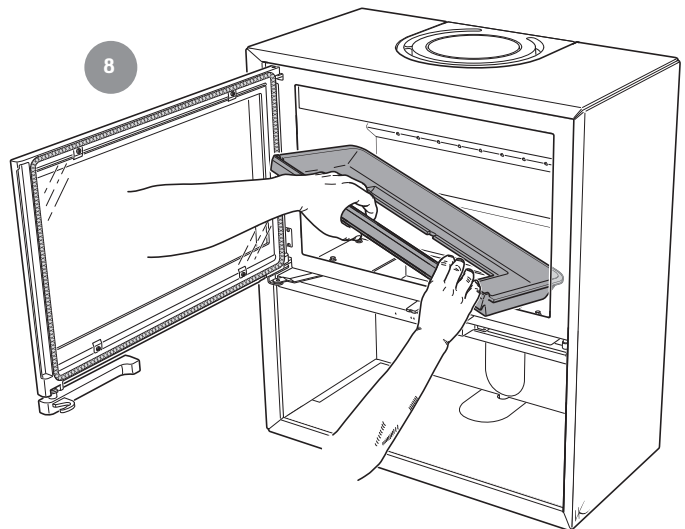



For installation in the UK and in smoke control areas

Mandatory for smoke control areas

Contura 310, 320 and 330, 7 kW woodburning stoves has been recommended as suitable for use in smoke control areas. This when burning wood logs and operated in accordance with these instructions and when fitted with a permanent stop to prevent closure of the air control unit beyond 31% open position.

The permanent stop must be installed if the appliance is to be used in a smoke control area, this stop must not be removed in smoke control areas, otherwise an offence will be committed if the appliance is used without the permanent stop in place.

Damper Blocker for C310, C320 and C330

