

# Installation Instructions



C 710

*Contura*

Declaration of performance according  
to Regulation (EU) 305/2011  
No. C710-CPR-160329-SE-1

# Contura

## PRODUCT

Product type Stove lit with solid biofuels  
Type designation Contura 710  
Manufacturing number See rating plate on the stove  
Intended area of use Heating of rooms in residential buildings  
Fuel Wood

## MANUFACTURER

Name NIBE AB / Contura  
Address Box 134, Skulptörvägen 10  
SE-285 23 Markaryd, Sweden

## CHECKS

According to AVCP System 3  
European standard EN 13240:2001 / A2:2004  
Test institute Rein-Ruhr Feuerstätten Prüfstelle, NB 1625,  
has checked declared performance and issued test report no. RRF-40 16 4237

## DECLARED PERFORMANCE

Essential characteristics	Performance	Harmonised technical specification
Reaction to fire	A1 WT	EN 13240:2001 / A2:2004
Minimum distance to combustible material	Rear: 100 mm Side: 450 mm Other safety distances according to the installation instructions	
Risk of falling embers	Pass	
Emissions from combustion	CO 0.1% NOx 103 mg/m <sup>3</sup> OGC 77 mg/m <sup>3</sup> PM 23 mg/m <sup>3</sup>	
Surface temperatures	Pass	
Cleaning options	Pass	
Mechanical durability	Pass	
Emissions of hazardous substances	Pass	
Nominal output	5 kW	
Efficiency	80%	
Flue gas temperature in connector at nominal output	315°C	

The undersigned is responsible for the manufacture and conformity with the declared performance.



**Niklas Gunnarsson**, Business area manager NIBE STOVES  
Markaryd, March 29, 2016



A warm welcome to Contura.

A warm welcome to the Contura family. We hope you will get a great deal of pleasure from your new stove. As a new owner of a Contura stove you have secured a product with timeless design and long service life. Contura also has combustion that is both environmentally friendly and efficient for the best heat production.

Read through these installation instructions carefully before installation. Read how to best light your stove in the lighting instructions.

Table of contents

Technical details	52
Prior to installation	52
Connection to chimney	53
Supply of combustion air	54
Installation distance	55
Installing	56
Removing the loose parts	58

**NOTE!**

**Report the installation of a stove to your local authority.**

The owner of the house is personally responsible for ensuring compliance with the mandatory safety requirements and must have the installation approved by a qualified inspector. Your local chimney sweep must also be informed about the installation as this will affect the routines for regular chimney-sweeping services.

**WARNING!**

**The stove becomes very hot**

During operation, certain surfaces of the stove become very hot and can cause burn injury if touched. Be aware of the strong heat radiated through the hatch glass. Placing flammable material closer than the safe distance indicated may cause a fire. Pyre lighting can cause quick gas ignition with the risk of damage to property and personal injury.

## Technical details

Output	3-7kW
Nominal output	5 kW
Efficiency	up to 80%

<b>Model</b>	<b>710</b>
Height (mm)	1151
Width (mm)	459
Depth (mm)	372
Weight (kg)	103

### Type approved in accordance with:

European standard EN-13240  
 NS 3059 (Norway)  
 DIN Plus, RRF-40 16 4237 (Germany)  
 Art. 15a B-VG (Austria)  
 Clean Air Act. (UK)

## Important to remember!

### Installation by authorised technician

This manual contains instructions about how the stoves must be assembled and installed. To ensure the function and safety of the stove, we recommend that the installation is carried out by an authorised technician. Contact one of our dealers who can recommend suitable technicians.

### Structural support

Check that the wood joists are strong enough to bear the weight of the stove and chimney. The stove and chimney can usually be placed on a normal wooden joist in a single occupancy house if the total weight does not exceed 400 kg.

### Building application

These main instructions may give guidance which would contravene national building regulations. Please refer to supplementary instructions or ask your local authority for advice regarding building regulations. Before installing a stove or erecting a chimney it is necessary for you to make a building application permission to your local authority.

### Hearth plate

Due to the risk of falling embers, a flammable floor must be protected by a hearth plate. It must extend 300 mm in front of the stove and 100 mm on each side of the stove, or have a 200 mm extension on each side of the opening. The hearth plate can consist of natural stone, concrete, metal plate or glass. A painted metal or glass hearth plate is available as an accessory for these models.

## Prior to installation

If the insert needs to be put down to be moved or if the pillar foot is to be installed, remove any loose components. This is described at the end of these installation instructions.

- 1 Fire bars
- 2 Grate disc
- 3 Heat deflector
- 4 Hearth cladding

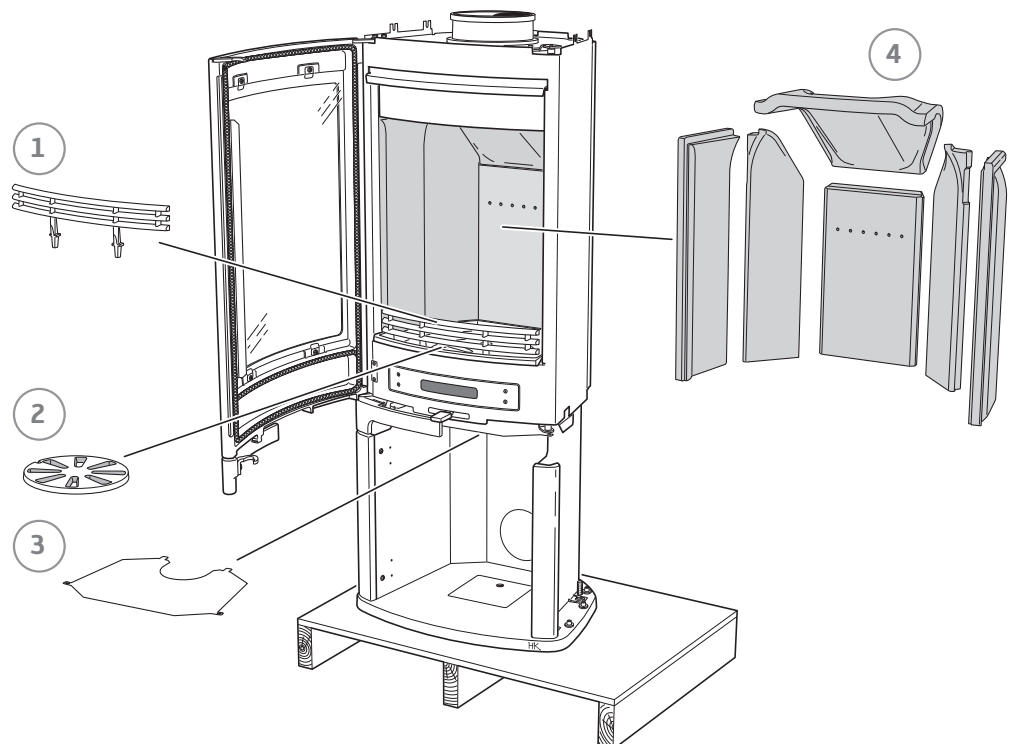

# Connection to chimney

- The stove meets the requirements for connecting to chimneys dimensioned for 350°C flue gas temperature.
- The external diameter of the connection sleeve is 150 mm.
- The stove requires a draft in the chimney of at least -12 Pa. The draft is affected both by the length and area of the chimney, and by how well sealed it is. Minimum recommended chimney length is 3.5 m and suitable cross section area is 150-200 cm<sup>2</sup> (140-160 mm in diameter).
- A flue with sharp bends and horizontal routing reduces the draught in the chimney. Maximum horizontal flue is 1 m, on the condition that the vertical flue length is at least 5 m.
- It must be possible to sweep the full length of the flue and the soot hatches must be easily accessible.
- Carefully check that the chimney is sealed and that there is no leakage around soot hatches and flue connections.

## Rear connection to a masonry chimney

The back panel must be installed before the stove is rear connected.

In the bag with these installation instructions are two wing screws for the cover.

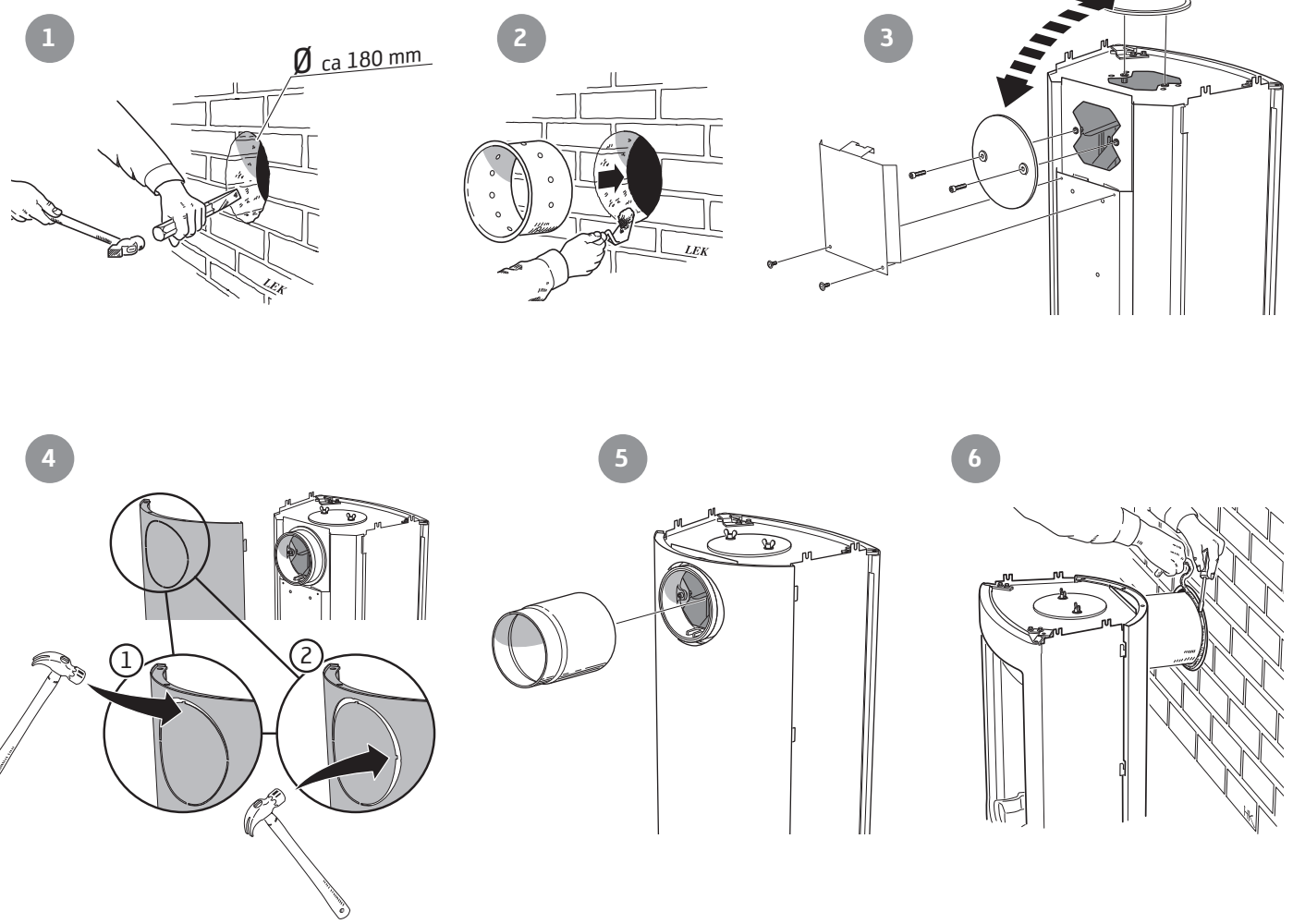

## Top connection to the chimney

The hot air grille must be installed before chimney top connection.

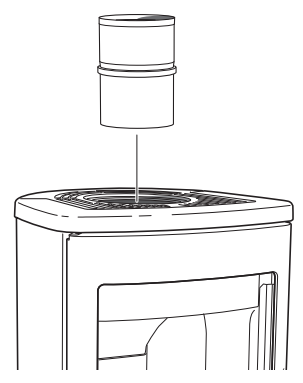

Make sure that the connector gasket does not work loose when the connection pipe is placed on the connector. If further sealing material is required, heat-resistant sealant may be used.

## Supply of combustion air

When a stove is installed in a room, the demand for air supply to the room increases. Air can be provided indirectly via a vent in the outer wall or via a duct from the outside that is connected to the connector on the underneath of the stove. The amount of air needed for combustion is  $25\text{m}^3/\text{h}$ .

The connector has an external diameter of 67 mm. When duct routing further than 1 m the pipe diameter must be increased to 100 mm and a correspondingly larger wall vent must be selected.

In hot areas the duct should be insulated with 30 mm mineral wool covered with a moisture inhibitor (plastic). It is important that the lead-in between the pipe and the wall (or floor) is sealed using jointing compound.

A 1 m length of condensation insulated ducting for combustion air is available as an accessory.

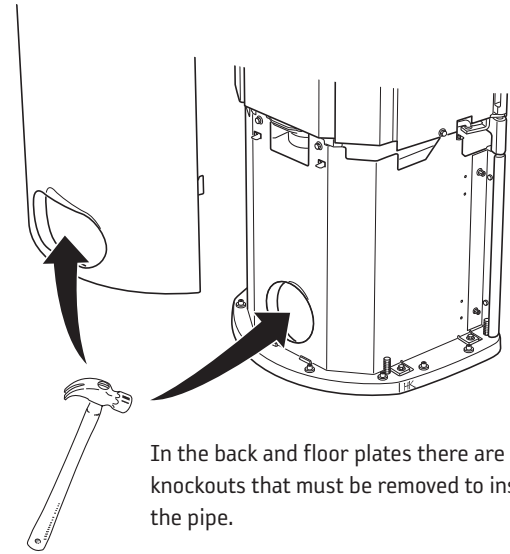

In the back and floor plates there are knockouts that must be removed to insert the pipe.



Leave a 40 mm gap between the condensation insulation and the bottom of the stove.

### Installation variants

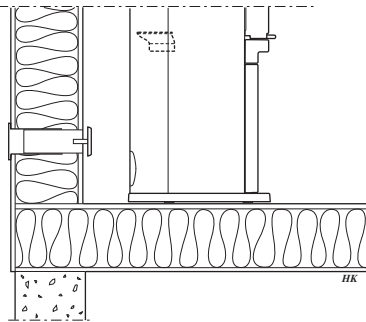

Indirect air supply through the external wall.

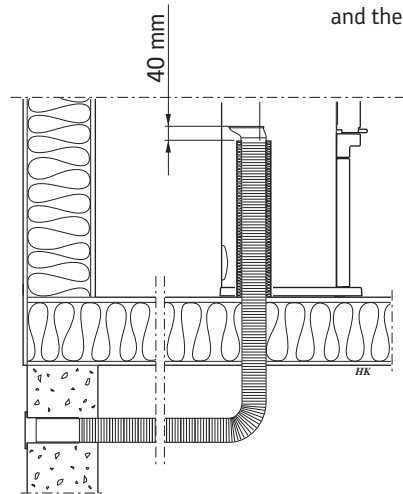

Through floor and wall-and-cavity foundation.

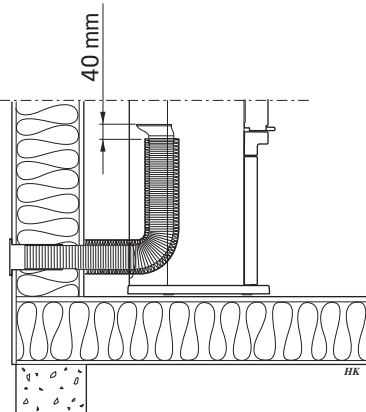

Through the external wall.

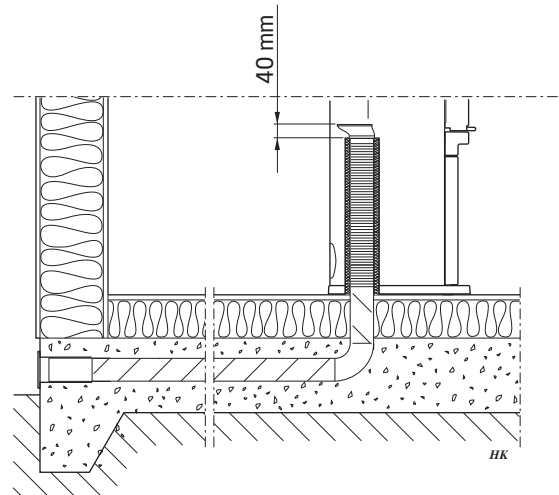

Through floor and foundation slab.

# Installation distances

## C 710

The minimum distance in front of the stove opening to combustible parts of the building or interior decoration must be at least 1 m.

The dimension diagrams only show the minimum permitted installation distances for the stove. When connecting to a steel flue, also note the safety distance requirements of the flue. The safety distance between an un-insulated flue and a combustible part of the building should be at least 450 mm.

- A = height from floor to chimney connection upwards
- B = height from floor to c/c chimney connection rear
- C = height from floor to air inlet
- D = height from floor to lower edge of hatch

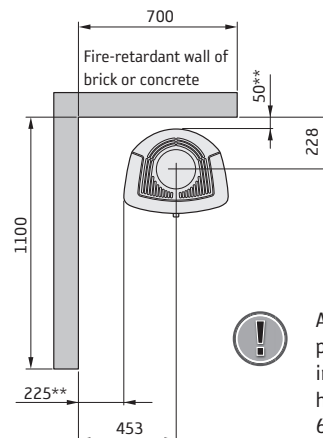
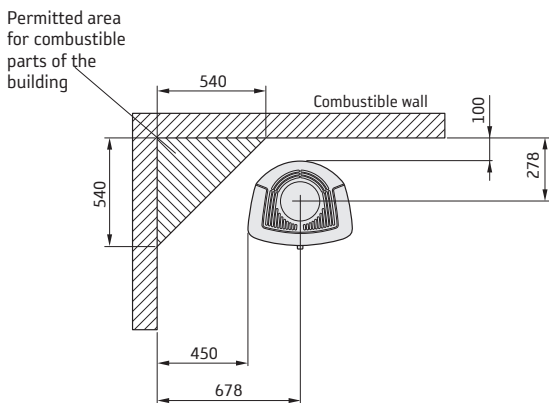
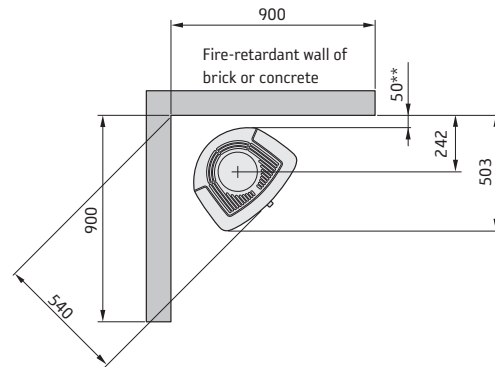
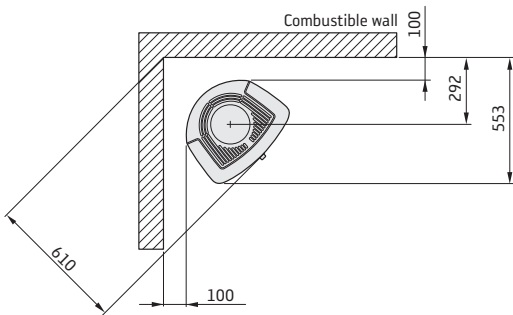
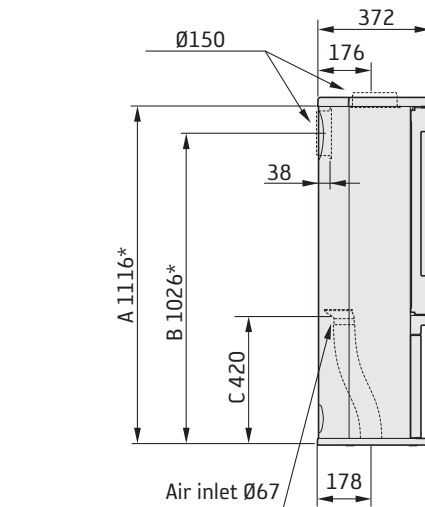
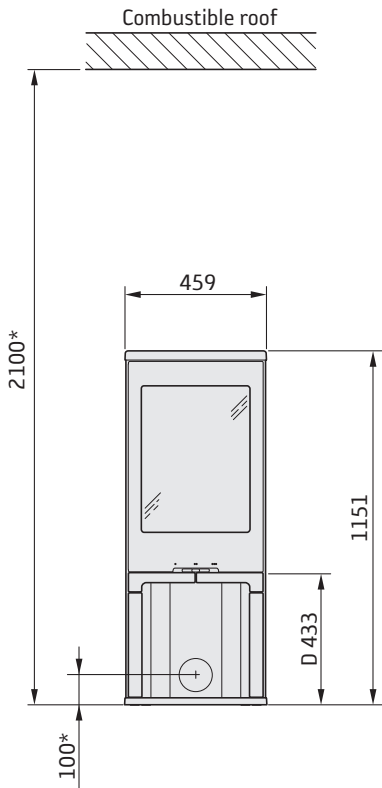

**!** A separate glass hearth plate (accessory) increases the connection height to the chimney by 6 mm.

\* If the stove is placed on a hearth plate made of glass for example (accessory), the height from the floor is affected by a distance corresponding to the thickness of the hearth plate. Also applies to separate glass hearth plates (accessory).

\*\* We recommended the same side distance as to combustible walls to prevent discolouration of painted non-flammable walls.

## Assembly

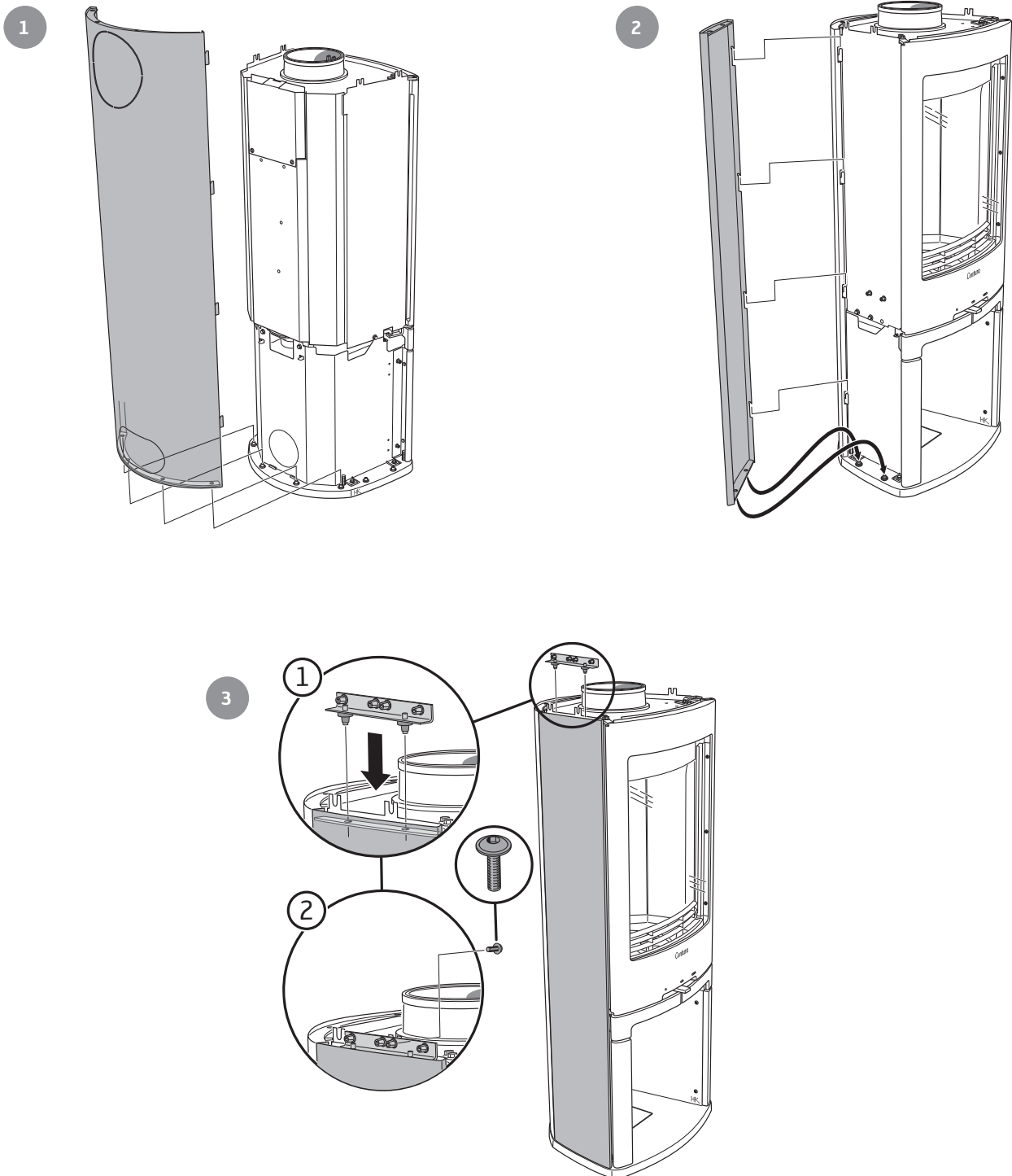

Final inspection of the installation

It is extremely important that the installation is inspected by an authorised chimney sweep before the stove is used. Also read the "Lighting instructions", before lighting for the first time.



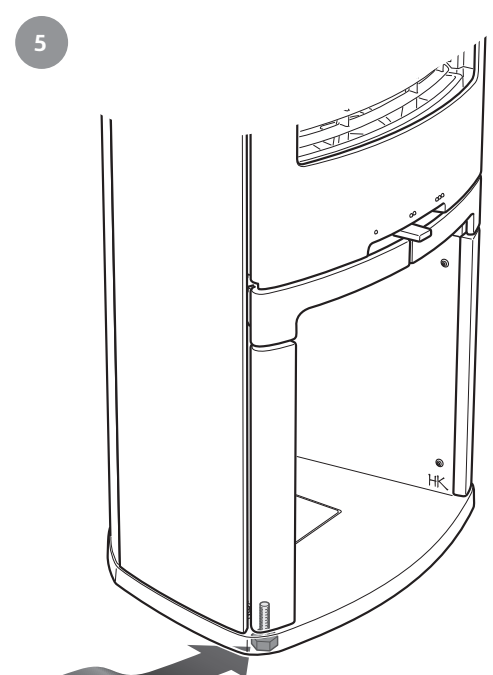

x4

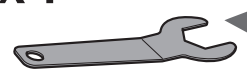

How to remove the heat deflector

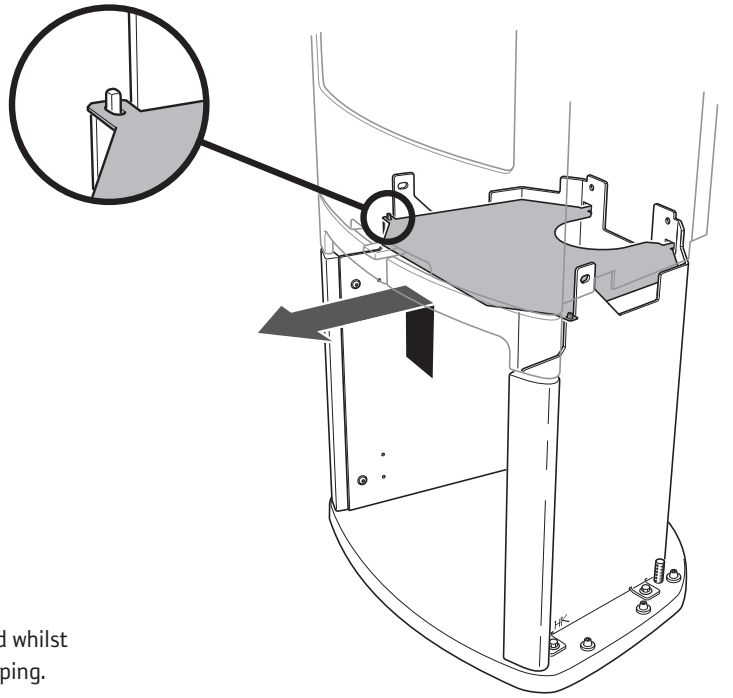

How to remove the hearth surround

Handle the vermiculite with care. Lift the smoke baffle with one hand whilst removing the sides. The side posts need not be removed when sweeping. Reinstall in reverse order

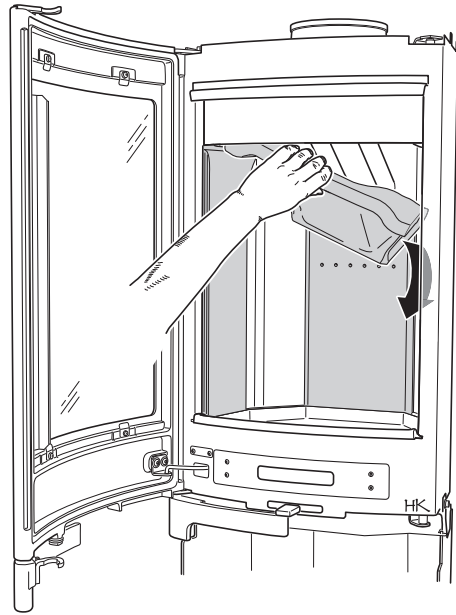
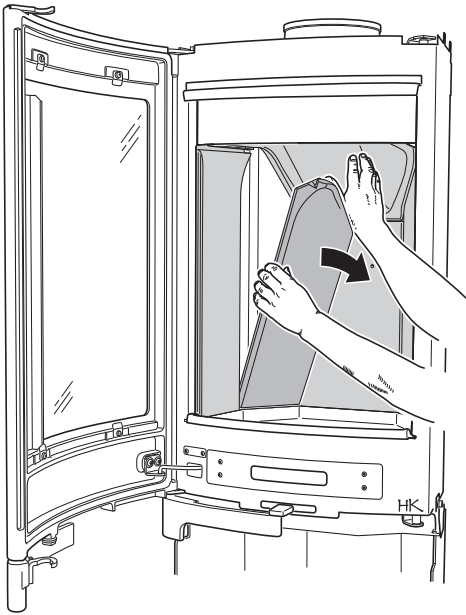



811278 IAV SE-EX C710-2  
2016-06-23

# *Contura*

NIBE AB · Box 134 · 285 23 Markaryd · Sweden  
[www.contura.eu](http://www.contura.eu)

Contura reserves the right to change dimensions and procedures described in these instructions at any time without special notice. The current edition can be downloaded from [www.contura.eu](http://www.contura.eu)