

Installation/Lighting INSTRUCTIONS



C51L

Contura

A warm welcome to Contura.

A warm welcome to the Contura family. We hope you will get a great deal of pleasure from your new stove. As a new owner of a Contura stove you have secured a product with timeless design and long service life. Contura also has combustion that is both environmentally friendly and efficient for the best heat production.

Read through these installation instructions carefully before installation. Read how to best light your stove in the lighting instructions.

Table of contents

General	5
Installation distance to walls and ceiling	6
Removing the loose components	8
Adjusting and connecting	9
Connection to the chimney	10
Lighting Instructions	11

NOTE!

Report the installation of a stove to your local authority.

The owner of the house is personally responsible for ensuring compliance with the mandatory safety requirements and must have the installation approved by a qualified inspector. Your local chimney sweep must also be informed about the installation as this will affect the routines for regular chimney-sweeping services.

WARNING!

The stove becomes very hot

During operation, certain surfaces of the stove become very hot and can cause burn injury if touched. Be aware of the strong heat radiated through the hatch glass. Placing flammable material closer than the safe distance indicated may cause a fire. Pyre lighting can cause quick gas ignition with the risk of damage to property and personal injury.

Declaration of performance according to Regulation (EU) 305/2011

No. C51-CPR-220901

Contura

PRODUCT

Type Wood burning stove
Trade name Contura 51L
Intended area of use Heating of rooms in residential buildings
Fuel Wood

MANUFACTURER

Name NIBE AB / Contura
Address Box 134, Skulptörvägen 10
SE-285 23 Markaryd, Sweden

VERIFICATION

According to AVCP System 3
European standard EN 13240:2001 / A2:2004 / AC:2007
Test institute Rein-Ruhr Feuerstätten Prüfstelle, NB 1625.

DECLARED PERFORMANCE

ESSENTIAL CHARACTERISTICS	PERFORMANCE	HARMONISED TECHNICAL SPECIFICATION
Fire safety	Pass	EN 13240:2001 / A2:2004 / AC:2007
Fire classification	A1	
Minimum distance to flammable materials	Rear: 150 mm Side: 500 mm Ceiling: 1370 mm Front: 1000 mm Floor: NPD Corner: 150 mm	
Fire hazard due to burning fuel falling out	Pass	
Cleanability	Pass	
Emissions from combustion	CO: 1500 mg/ m ³ NOx: 200 mg/ m ³ OGC: 120 mg/ m ³ PM: 40 mg/ m ³	
Surface temperatures	Pass	
Temperature on the handle	NPD	
Mechanical resistance	Pass	
Temperature in the space for wood storage	NPD	
Nominal output	5,0 kW	
Efficiency	81,1%	
Flue gas temperature at nominal output	266°C	
Flue gas temperature in flue spigot	295°C	

The undersigned is responsible for the manufacture and conformity with the declared performance.



Niklas Gunnarsson, Business area manager NIBE STOVES
Markaryd, 1st September 2022



EU Declaration of Conformity

Manufacturer	NIBE AB / Contura
Address	Box 134, Skulptörvägen 10 285 23 Markaryd, Sweden
E-Mail	info@contura.se
Website	www.contura.eu
Telephone	+46 433 275100

Contura

THIS DECLARATION OF CONFORMITY IS ISSUED UNDER OUR SOLE RESPONSIBILITY FOR THE FOLLOWING PRODUCT:							
Trade name	Contura 51L						
Identification of product	www.contura.eu						
THE OBJECT OF THE DECLARATION DESCRIBED ABOVE IS IN CONFORMITY WITH -							
THE RELEVANT UNION HARMONIZATION LEGISLATION:				THE RELEVANT HARMONIZED STANDARDS:			
DIR 2009/125/EC				EN 13240:2001/A2:2004/AC:2007			
REG (EU) 2015/1185				CEN/TS 15883:2010			
REG (EU) 2015/1186							
REG (EU) 2017/1369							
REG (EU) 305/2011							
TECHNICAL DOCUMENTATION							
Indirect heating functionality:	No						
Direct heat output:	5,0 kW						
Energy Efficiency Index (EEI):	107,6						
Test report	RRF 41 07 1261, NB 1625						
FUEL	PREFERRED FUEL	OTHER SUITABLE FUEL	η_s (%)	EMISSIONS AT NOMINAL HEAT OUTPUT			
				PM	OGC	CO	NO _x
mg/ Nm ³ (13% O ₂)							
Wood logs with moisture content 25%	Yes	No	71,1	40	120	1500	200
Compressed wood with moisture content <12%	No	Yes	71,1	40	120	1500	200
Other woody biomass	No	No					
Non-wood biomass	No	No					
Anthracite and dry steam coal	No	No					
Hard coke	No	No					
Low temperature coke	No	No					
Bituminous coal	No	No					
Lignite briquettes	No	No					
Peat briquettes	No	No					
Blended fossil fuel briquettes	No	No					
Other fossil fuel	No	No					
Blended biomass and fossil fuel briquettes	No	No					
Other blend of biomass and solid fuel	No	No					
CHARACTERISTICS WHEN OPERATING WITH THE PREFERRED FUEL							
ITEM	SYMBOL	VALUE	UNIT	ITEM	SYMBOL	VALUE	UNIT
HEAT OUTPUT				USEFUL EFFICIENCY, BASED ON NET CALORIFIC VALUE (NCV)			
Nominal heat output:	P_{nom}	5,0	kW	Useful efficiency at nominal heat output	$\eta_{th,nom}$	81,1	%
AUXILIARY ELECTRICITY CONSUMPTION				TYPE OF HEAT OUTPUT/ROOM TEMPERATURE CONTROL			
At nominal heat output	$e_{l,max}$	-	kW	Single stage heat output, no room temperature control	Yes		
At minimum heat output	$e_{l,min}$	-	kW	Two or more manual stages, no room temperature control	No		
In standby mode	$e_{l,SB}$	-	kW	With mechanic thermostat room temperature control	No		
				With electronic room temperature control	No		
				With electronic room temperature control plus day timer	No		
				With electronic room temperature control plus week timer	No		
				OTHER CONTROL OPTIONS			
				Room temperature control, with presence detection	No		
				Room temperature control, with open window detection	No		
				With distance control option			
Specific precautions for assembly, installation, or maintenance.	Fire protection and safety distances to combustible building materials must be observed under all circumstances. A sufficient supply of combustion air must always be guaranteed. Air suction systems can interfere with the combustion air supply.						

The undersigned is responsible for the manufacture and conformity with the declared performance.



Niklas Gunnarsson, Business area manager NIBE STOVES
Markaryd, January 1, 2022

General

This manual contains instructions about how Contura 51L must be assembled and installed.

To guarantee the function and safety of the stove we recommend that it is installed by a professional. Our Contura agents can recommend a suitable installer.

The stove is type approved and must be connected to a chimney dimensioned for at least 350°C. The connector on the stove is suitable for pipes with an inner diameter of Ø150 mm and an outer diameter of maximum Ø154 mm. The room or space containing a stove shall have a permanent air supply sufficient to ensure proper combustion, to determine correct amount of air supply use current edition of Building Regulations.

Technical data

Output	4 kW
Nominal output	5 kW
Efficiency level	79%
Flue gas mass flow	6,0 g/s

Model	C51L
Weight (kg)	124
Width (mm)	495
Depth (mm)	420
Height (mm)	630

The connector's inner diameter is Ø154 mm
 Type approved in accordance with:
 European standard EN-13240
 Swedish environmental and quality marking,
 Swan marked No 378 001 and
 P-marking cert. no. 22 03 16
 (N) NS 3059, Cert.nr SINTEF 110-0257
 (DE/A) DINplus, Art. 15a B-VG RRF-40 07 1261

DEFRA exempted

The stove can be used in Smoke Control Areas. Smouldering, i.e. reduced air supply, are prevented by blocking the combustion damper of 4 kW output.

Building application

Before installing a stove or erecting a chimney it is necessary for you to apply for planning permission from your local authority. Ask your local authority for advice regarding building regulations and the application.

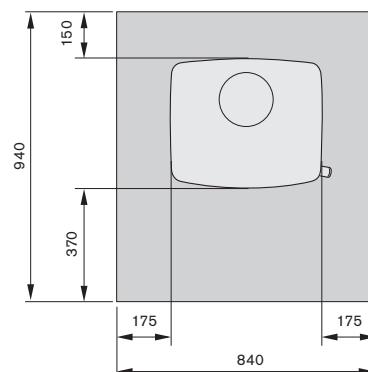

Hearth dimensions

The stove must be placed on a constructional heart with the minimum dimensions shown beside, installations distances must also be according to diagrams on next page. Check that the building has enough bearing capacity for the heart, stove and chimney. The stove can be loaded with maximum 100 kg of chimney.

Chimney

Note! The stove installation and connection to a chimney must be accomplished with the current edition of Building Regulations. We recommend that you consult a local chimney sweep before the installation to make sure that the chimney is in good condition.

The stove requires a draught in the chimney of at least -12 Pa. The draught is affected both by the length and area of the chimney, and by how well sealed it is. The recommended minimum flue length is 3.5 m and its diameter should be Ø130 to Ø150 mm. Carefully check that the chimney is sealed and that there is no leakage around soot hatches and flue connections.

Note that a flue with sharp bends and horizontal routing reduces the draught in the chimney. Maximum horizontal flue is 1 m, on the condition that the vertical flue length is at least 5 m. It must be possible to sweep the full length of the flue and the soot hatches must be easily accessible.

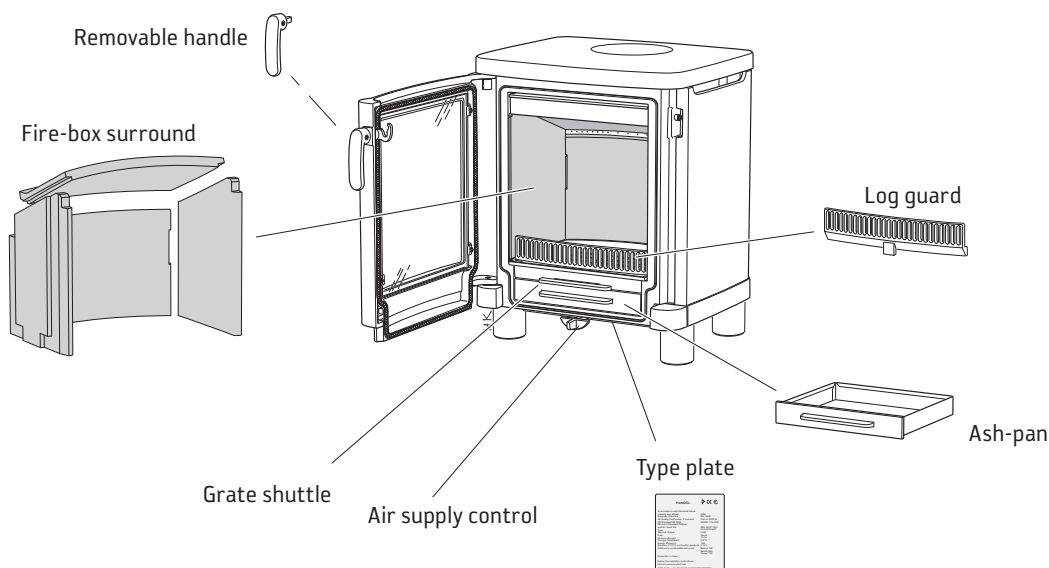

Installation distance to walls and ceiling

C51L

Move the stove in position and check that the installation distances given in the diagrams are met. The minimum distance between the stove opening and combustible parts of the building or décor must be at least 1 m.

When top connecting a steel flue please refer to the relevant manufacturer's installation instructions. Observe the safety distances to combustible material that steel flues require.

- A = height from floor to top flue connection
- B = height from floor to c/c smoke outlet rear
- C = distance from back to c/c air inlet, Ø64
- D = distance from back to smoke outlet rear

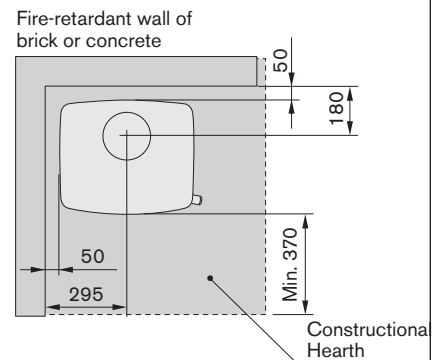
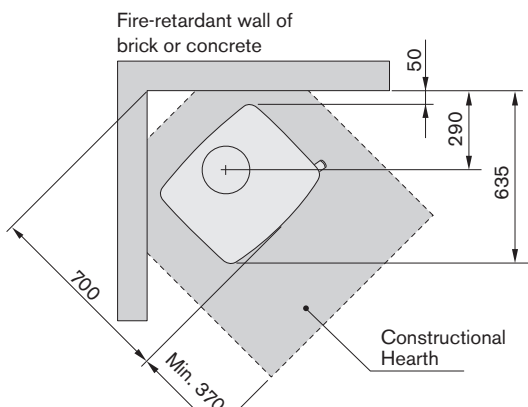
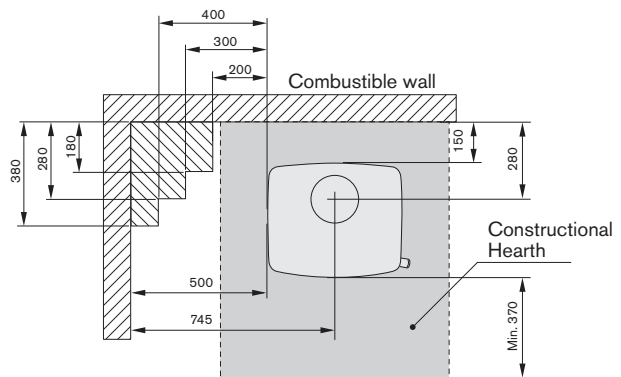
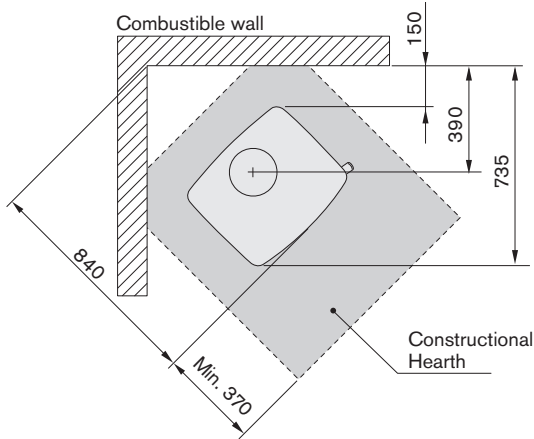
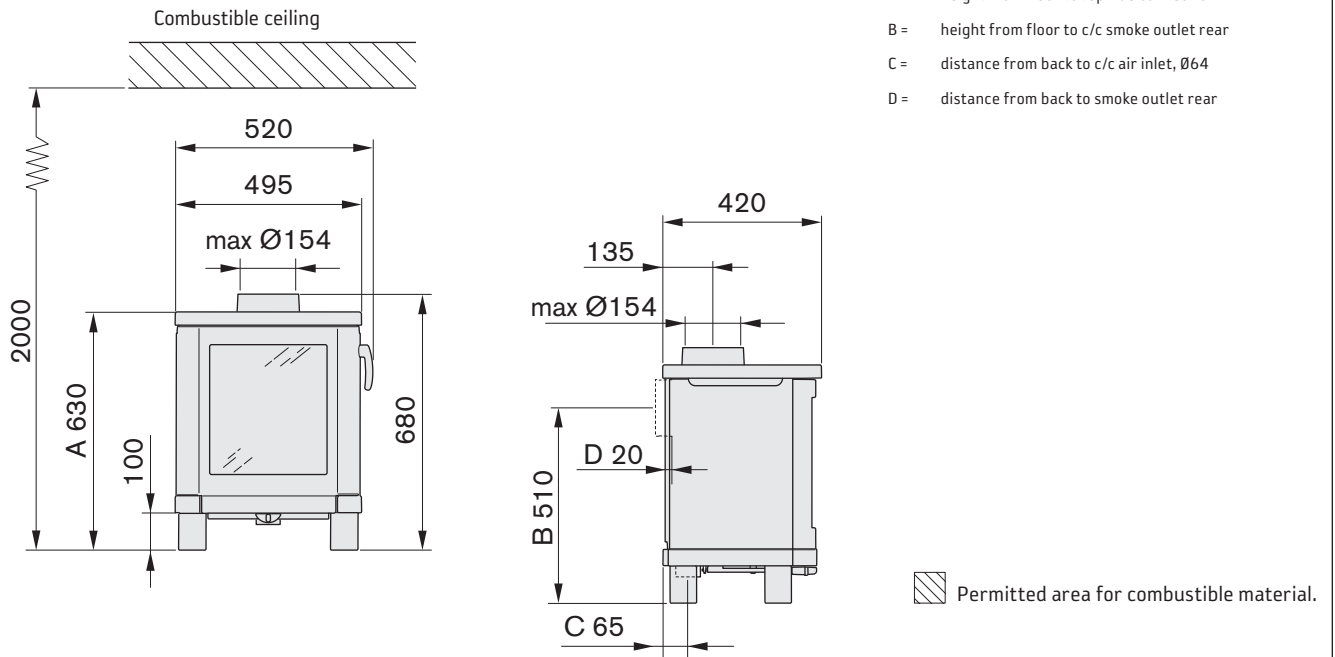

Removing the loose components

Fire bars

Lift the fire bars straight up, clean the ash from the guide groove in the stove base plate before repositioning it in position.

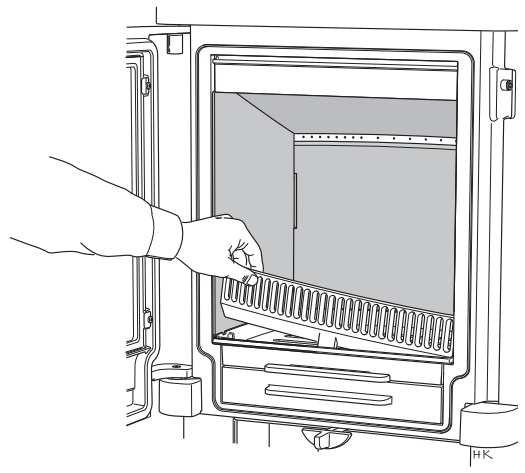

Fire box surround

When sweeping, the smoke baffle must be lifted out, this can be done when one side has been dismantled.

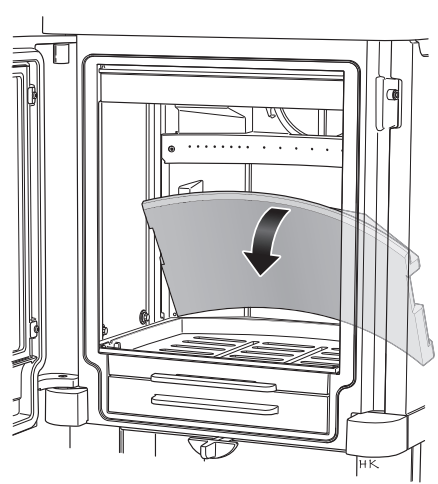
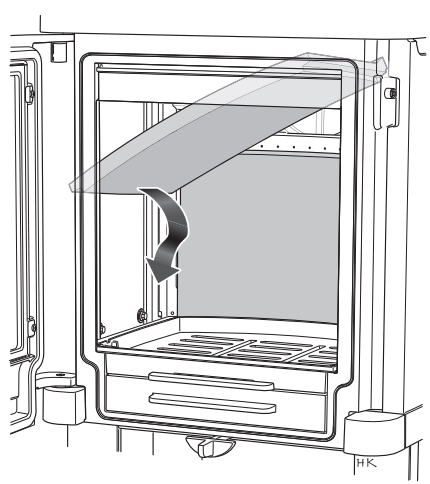
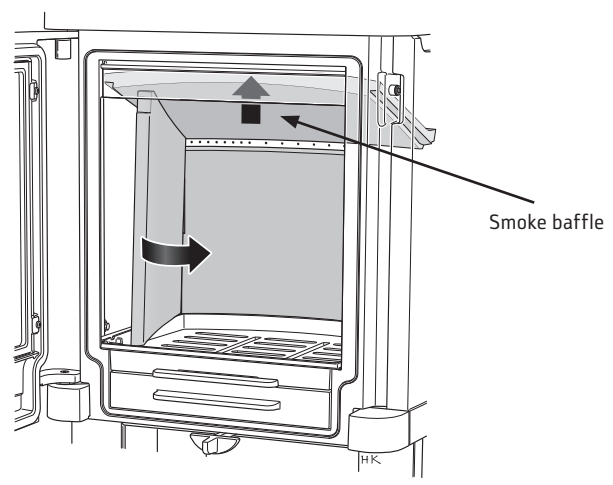
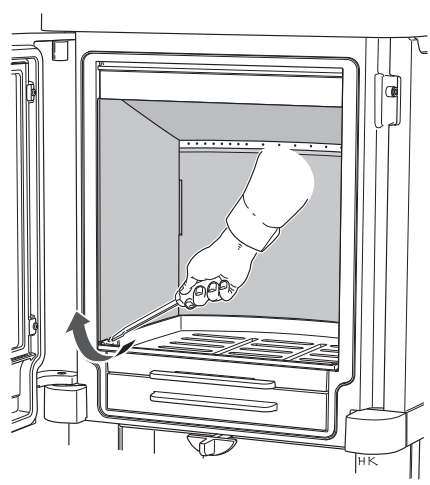

Removing the loose components

Stove base plate

The stove base plate is lifted out when all the cladding has been removed.

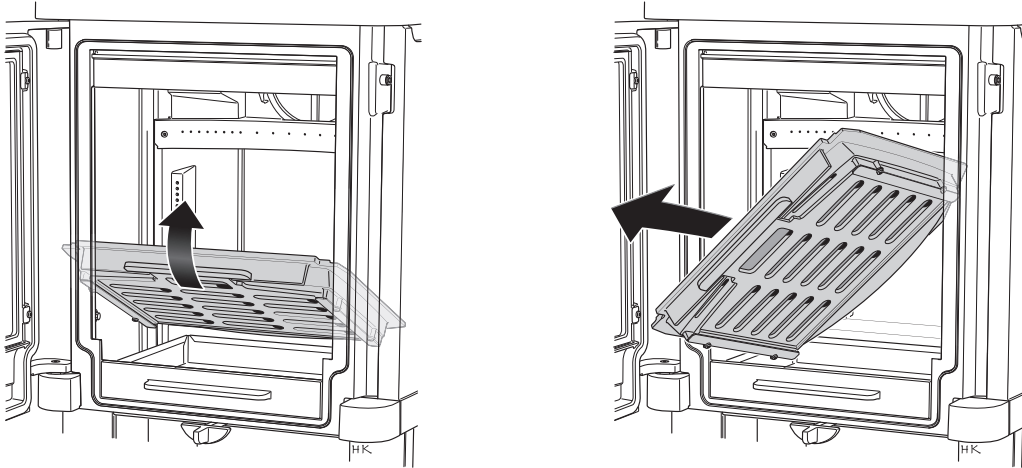

Fixed or removable handle

The stove handle is fitted on delivery. To make the handle removable, replace the screw for the lock hook with the shorter screw supplied.

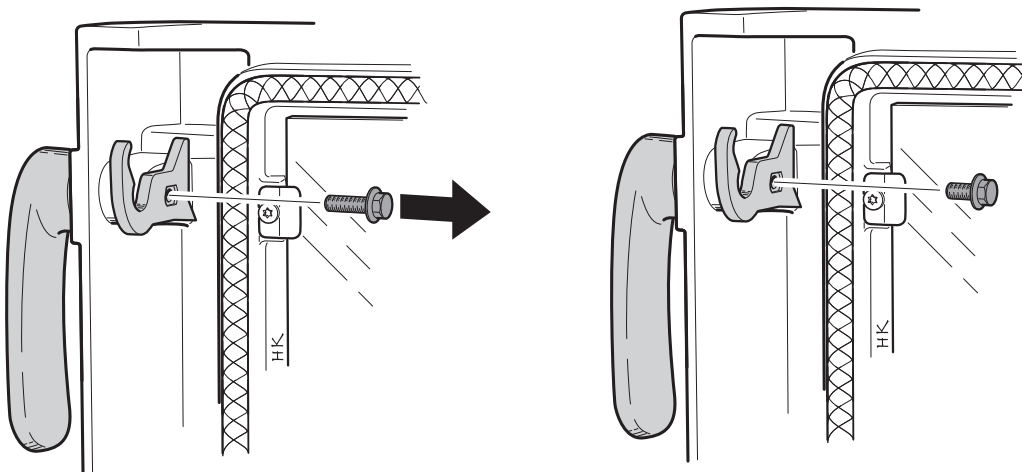

Adjusting and connecting

Preparations before rear connection

The stove is prepared for top connection on delivery. When connecting from the rear, the cover and connection must be swapped around.

- Dismantle the cladding as instructed previously, see page 6-7.
- Tap out the knock out in the stove's back panel, remember to protect the floor.
- Then unscrew both the connector and the cover.
- Switch places and reinstall the screws.

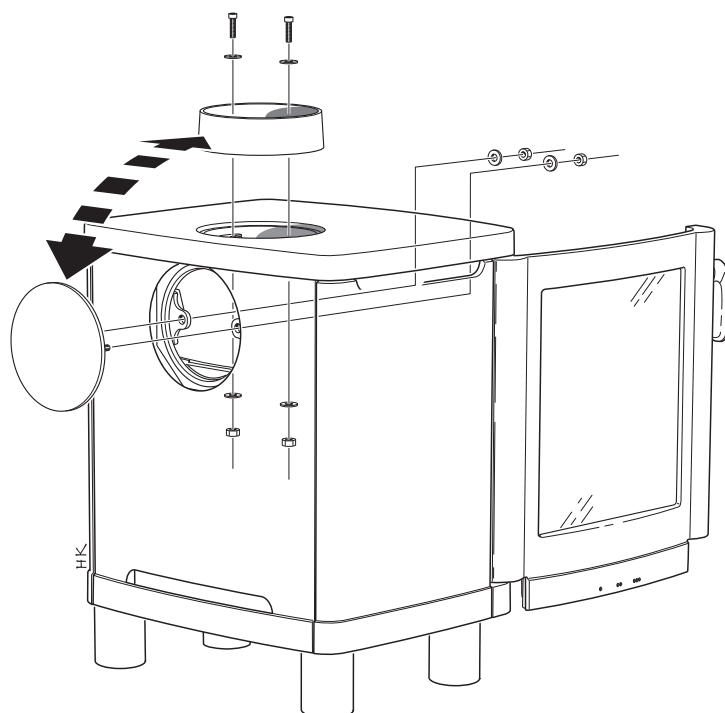
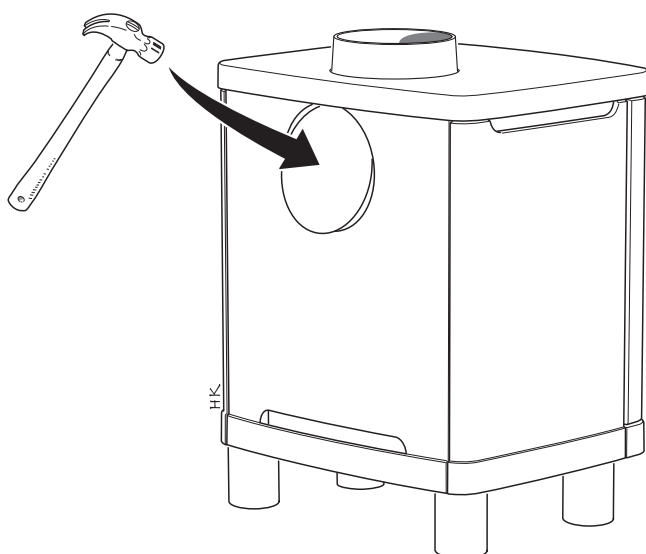

Connection to the chimney

Adjusting the stove

- Position the stove on the hearth plate.
- Adjust the height of the four adjustable feet until the stove is horizontal.

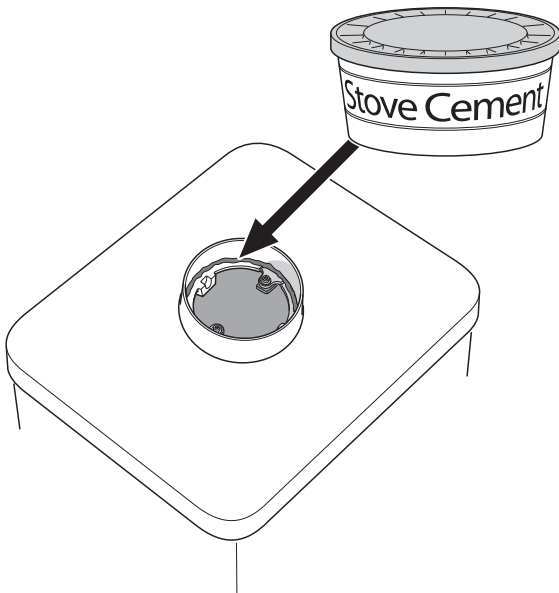

After the stove has been adjusted and positioned according to the installation distances, connection to the chimney is carried out.

Put stove cement inside the flue connection and press the start pipe into the connection.

Continue the chimney installation according to the chimney installation instructions.

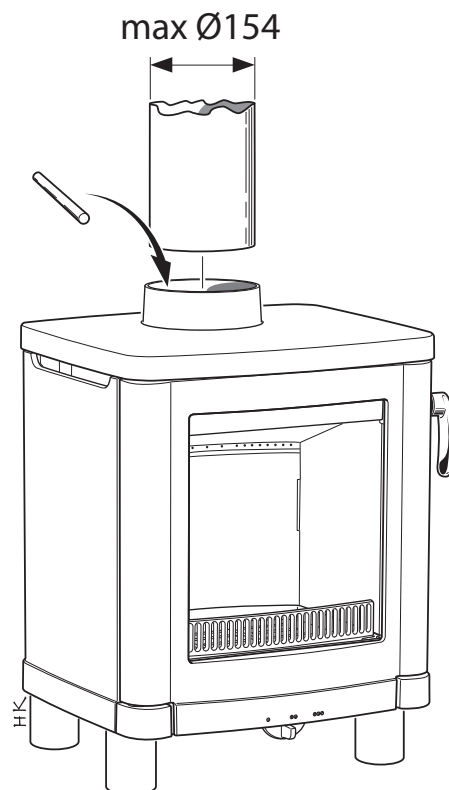
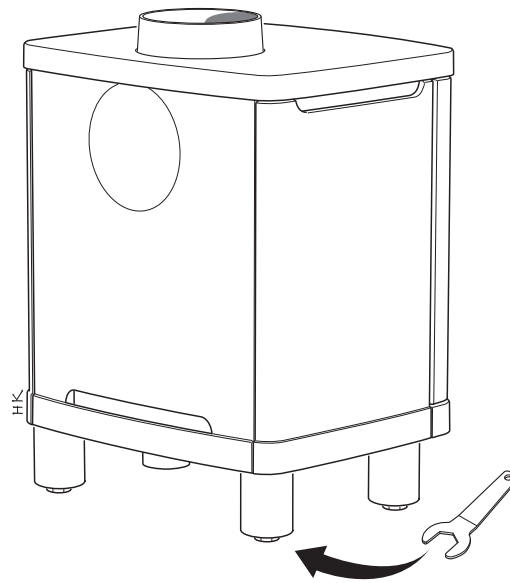

LIGHTING IN THE RIGHT WAY

It is important that the correct amount of wood is used, especially when lighting. If you are lighting the fire for the first time you should use a set of scales to see how much 2 kg kindling is. Also check what the normal and maximum weights look like.

The tiled stove is only intended for use with the door closed and it is only then that the hot air flushing of the glass surfaces occurs. Always open the door carefully and slowly to prevent blow back because of the changing pressure in the stove.

The function of stoves differs depending on the draught conditions in the chimney. Achieving the correct setting for the combustion air damper usually takes a few attempts. In order to obtain a good bed of embers, there should always be a thin layer of ash and charred pieces in the tiled stove.

LIGHTING FOR THE FIRST TIME

The first time that the stove is lit, lighting should be terminated after the initial fire has caught. This is so that the cement that is used as sealant is able to harden. After that the stove can be used according to the instructions below with lighting and log feeding.

Correctly sized wood

Note that if too little kindling is used when lighting, or if the wood is too thickly cut, the fire box will not reach the correct operating temperature. Incorrect lighting can lead to poor combustion with heavy sooting and may result in the fire going out when the door is shut.

Kindling wood: Finely chopped wood
Length: 25-35 cm
Diameter: 3-4 cm
Weight per lighting: 2.0 kg (approx. 10 - 12 finely chopped pieces)

Feeding Wood: Chopped wood
Length: 25-35 cm
Diameter: 6-7 cm
Normal weight: 1.5 kg/hour
Max weight: 2.2 kg/hour (2-3 logs per load)

Lighting

If your house has mechanical exhaust air ventilation you will need to open a window near the stove before lighting the fire. Leave the window open for a few minutes until the fire has caught.

1. Open the controls for the combustion air fully.
2. Place some newspaper or a fire lighter block, and approximately 2 kg kindling in the middle of the stove. The wood should be piled alternately across and lengthways.
3. Light the fire.
4. The hatch is set to the lighting position, that is the lower locking hook must be hooked securely around the lock reel. When the fire has caught fully after approx 10-15 minutes, close the doors completely (see figures to right). The first load of logs should not be put on until the start up fire has become a glowing bed of embers.

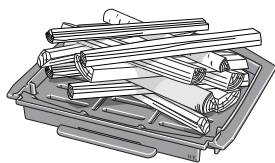

Wood loading

1. Open the door handle slightly and let the vacuum in the firebox equalise for a few seconds before opening the door completely.
2. Add 2-3 logs of a combined weight of approx 1.5-2.2 kg. One log is placed diagonally and one or two logs are placed parallel to the back, see illustration to the right. Then close the door.
3. The combustion damper must be completely open for 3-5 minutes until the logs turn black and catch fire. If you wish for slower combustion, the supply of combustion air can now be reduced. The conditions for controlling combustion vary depending on the temperature in the stove and the draft in the chimney.
4. The lowest output of 4 kW is usually obtained when the combustion damper is 30% open and two logs are lit. In this operating mode it is important that the combustion air damper is fully open for the first 3-5 minutes so that the wood has the chance to ignite fully before the supply of combustion air is reduced. A condition of being able to control the heat output is a thick bed of embers and a high temperature in the firebox. When the fire has burnt down to embers is the time to add more wood.

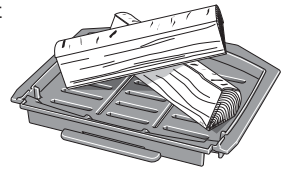

DEFRA exempted

The stove can be used in Smoke Control Areas. Smouldering, i.e. reduced air supply, are prevented by blocking the combustion damper of 4 kW output.



QUICK LIGHTING

It is important that the wood catches fire quickly. Quick lighting is achieved by opening the combustion air damper fully or by leaving the door in the lighting position for a moment. Smouldering, i.e. reduced.

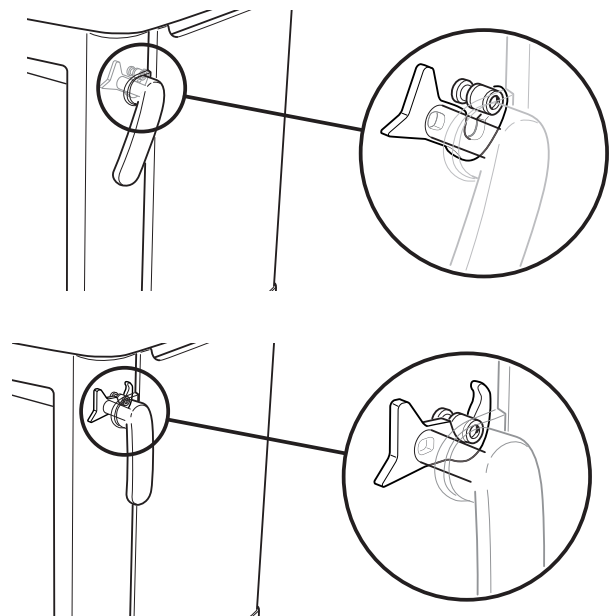

CHOICE OF FUEL

All sorts of logs, such as birch, beech, oak, elm, ash, conifers and fruit trees can be used as fuel in the stove. Different types of wood have different density, the higher the density the higher the energy value. Oak, beech and birch have the highest density.



The wood's moisture content

Fresh wood is about 50 per cent water. Some of the water circulates freely between the fibres and some of the water is bound in the cells. The wood must always be dried so that the free water evaporates. The timber is ready for use when the moisture content has fallen below 20 %. If wood with a higher moisture content is lit, a large part of the energy content of the wood is used boiling off the water. If the wood is damp, the combustion is also poor, layers of soot and tar

build up in the chimney and could, at worst, lead to a chimney fire. In addition, it causes the glass of the tiled stove to soot and may cause discomfort to those living nearby.

To ensure thoroughly dry wood, the wood should be cut in the winter and stored, well aired, under a roof. Never cover the wood pile with a tarpaulin to the ground. The tarpaulin will then act as a sealed cover and the wood will be prevented from drying. Always store a small amount of wood indoors for several days before use, so that the surface moisture has time to evaporate.

You must NOT burn the following

Under no circumstances may pressure impregnated wood, painted or glued wood, chipboard, plastic or colour brochures be used as fuel. All these materials can create hydrochloric acid and heavy metals that are damaging both to the environment and the stove. Hydrochloric acid can also attack the steel in the chimney or the mortar in a stone built chimney.

STOVE MAINTENANCE

The glass may become sooty with use, even if the fire is lit with dry wood with a moisture content of 15 – 20%. Wiping with dry paper is often sufficient when cleaning regularly. If the soot has been on the glass for longer it can be removed using cleaning agent or a specific soot removal agent. These cleaning agents can be purchased at your local supermarket or your local stove dealer.

Never use cleaning agents that contain any abrasives, these can damage the glass.

Ensure that no embers remain when removing ash from the stove. The ash must be stored in a fireproof container with a lid for at least a week before being disposed of.

Soapstone can be cleaned using washing-up liquid or wiped with pure acetone. Do not place flammable objects or candles on the soapstone.

The grate and other cast iron components can be cleaned using a wirebrush.

It is important that the gaskets are checked from a combustion point of view, because worn gaskets reduce combustion because the stove draws additional air.

Painted parts of the stove can be cleaned with a damp cloth and, if necessary, a little washing-up liquid. Damage, such as scratches, to painted parts can be repaired using Contura touch up paint. Contact your dealer.

Because there is a constant flow of air through the stove, cold room air is drawn in and hot air released, dust can gather behind and under the stove. Therefore, one should regularly clean under and behind the stove.

AVOID TOO LARGE A FIRE

The fire should not be too big. Large fires are uneconomic and also produce high smoke temperatures that can damage the stove and the chimney. The recommended amount of wood is 1.5 kg/hour and the maximum permitted is 2.2 kg/hour and then refers to burning split birch or other broadleaf wood with 18% moisture content.

When lighting the same weight of conifer wood, significantly higher stove temperatures are reached. Maximum fire for long periods reduces the life of the stove and exceeding the permitted wood amounts can lead to damage to parts of the stove and the warranty being invalidated.



Managing waste

The stove packaging is cardboard, wood and a small amount of plastic. The materials must be sorted and recycled.

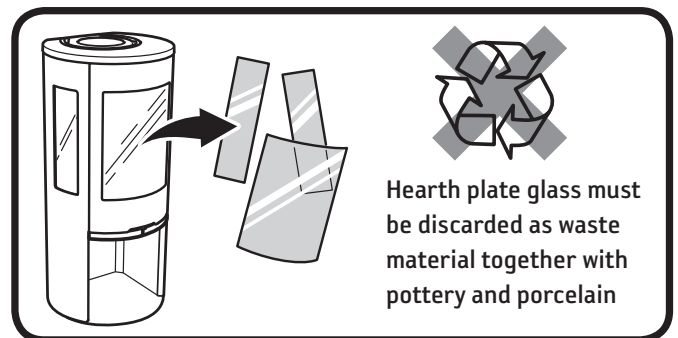

Hearth plate glass must be discarded as waste material together with pottery and porcelain

UK Smoke control areas

The Contura 51L stove has been recommended as suitable for use in smoke control areas when burning wood logs and operated in accordance with these instructions and when fitted with a permanent stop to prevent closure of the air control vent beyond the 30% open position when sold into smoke control areas. The instructions for modifying the air control with the permanent stop (damper blocker) are provided at page 16.

THE CLEAN AIR ACT 1993 AND SMOKE CONTROL AREAS

Under the Clean Air Act local authorities may declare the whole or part of the district of the authority to be a smoke control area. It is an offence to emit smoke from a chimney of a building, from a furnace or from any fixed boiler if located in a designated smoke control area. It is also an offence to acquire an "unauthorised fuel" for use within a smoke control area unless it is used in an "exempt" appliance ("exempted" from the controls which generally apply in the smoke control area).

In England appliances are exempted by publication on a list by the Secretary of State in accordance with changes made to sections 20 and 21 of the Clean Air Act 1993 by section 15 of the Deregulation Act 2015.

In Scotland appliances are exempted by publication on a list by Scottish

Ministers under section 50 of the Regulatory Reform (Scotland) Act 2014. Similarly, in Northern Ireland appliances are exempted by publication on a list by the Department of Agriculture, Environment and Rural Affairs under Section 16 of the Environmental Better Regulation Act (Northern Ireland) 2016. In Wales appliances are exempted by regulations made by Welsh Ministers.

Further information on the requirements of the Clean Air Act can be found here: <https://www.gov.uk/smoke-control-area-rules>

Your local authority is responsible for implementing the Clean Air Act 1993 including designation and supervision of smoke control areas and you can contact them for details of Clean Air Act requirements.

USER OPERATING INSTRUCTIONS

Please read these important notices before referring to the main instruction for detailed operating instructions.

Stove performance

Refer to the main instruction manual for details of the stove's performance.

Recommended fuels:

The stoves have a refuelling interval of 0.75h to achieve the nominal rated output. Wood logs should be seasoned with a moisture content of around 30%.

Refuelling on to a low fire bed:

If there is insufficient burning material in the firebed to light a new fuel charge, excessive smoke emission can occur. Refuelling must be carried out onto a sufficient quantity of glowing embers and ash that the new fuel charge will ignite in a reasonable period. If there are too few embers in the fire bed, add suitable kindling to prevent excessive smoke.

Fuel overloading:

The maximum amount of fuel specified in this manual should not be exceeded, overloading can cause excess smoke.

Operation with door left open:

Operation with the door open can cause excess smoke. The appliance must not be operated with the appliance door left open except as directed in the instructions.

HEALTH AND SAFETY PRECAUTIONS

Special care must be taken when installing the stove such that the requirements of the Health and Safety at Work Act are met.

Handling

Adequate facilities must be available for loading, unloading and site handling.

Fire Cement

Some types of fire cement are caustic and should not be allowed to come into contact with the skin. In case of contact wash immediately with plenty of water.

Asbestos

This stove contains no asbestos. If there is a possibility of disturbing any asbestos in the course of installation then please seek specialist guidance and use appropriate protective equipment.

Metal Parts

When installing or servicing this stove care should be taken to avoid the possibility of personal injury.

IMPORTANT WARNING

This stove must not be installed into a chimney that serves any other heating appliance.

There must not be an extractor fan fitted in the same room as the stove as this can cause the stove to emit fumes into the room.

Properly installed, operated and maintained this stove will not emit fumes into the dwelling. Occasional fumes from de ashing and re fuelling may occur. However, persistent fume emission is potentially dangerous and must not be tolerated. If fume emission does persist, then the following immediate action should be taken:

- (a) Open doors and windows to ventilate the room and then leave the premises.
- (b) Let the fire go out.
- (c) Check for flue or chimney blockage and clean if required.
- (d) Do not attempt to relight the fire until the cause of the fume emission has been identified and corrected.
If necessary seek expert advice.

The most common cause of fume emission is flueway or chimney blockage. For your own safety these must be kept clean at all times.

PREPARATORY WORK AND SAFETY CHECKS

Chimney

In order for the stove to perform satisfactorily the chimney height must be sufficient to ensure an adequate draught of approximately 15 Pa so as to clear the products of combustion and prevent smoke problems into the room.

NOTE: A chimney height of not less than 4.5 metres measured vertically from the outlet of the stove to the top of the chimney should be satisfactory. Alternatively the calculation procedure given in EN 13384-1 may be used as the basis for deciding whether a particular chimney design will provide sufficient draught. BS EN 15287-1:2007 gives additional details.

The outlet from the chimney should be above the roof of the building in accordance with the provisions of Building Regulations Approved Document J.

If installation is into an existing chimney then it must be sound and have no cracks or other faults which might allow fumes into the house. Older properties, especially, may have chimney faults or the cross section may be too large i.e. more than 230 mm x 230 mm. Remedial action should be taken, if required, seeking expert advice, if necessary. If it is found necessary to line the chimney then a flue liner suitable for solid fuel must be used in accordance with Building Regulations Approved Document J.

Any existing chimney must be clear of obstruction and have been swept clean immediately before installation of the stove. If the stove is fitted in place of an open fire then the chimney should be swept one month after installation to clear any soot falls which may have occurred due to the difference in combustion between the stove and the open fire.

If there is no existing chimney then any new system must be to the designation described above and in accordance with Building Regulations Approved Document J.

A single wall metal fluepipe is suitable for connecting the stove to the chimney but is not suitable for use as the complete chimney. The chimney and connecting fluepipe must have a minimum diameter of 150 mm and its dimension should be not less than the size of the outlet socket of the stove.

Any bend in the chimney or connecting fluepipe should not exceed 45°. 90° bends should not be used.

Combustible material should not be located where the heat dissipating through the walls of fireplaces or flues could ignite it. Therefore when installing the stove in the presence of combustible materials due account must be taken of the guidance on the separation of combustible material given in Building Regulations Approved Document J and also in these stove instructions.

If it is found that there is excessive draught in the chimney then a draught stabiliser should be fitted. Fitting of a draught stabiliser will affect the requirement for the permanent air supply into the room in which the stove is fitted in accordance with Approved Document J (see also combustion air supply).

Adequate provision e.g. easily accessible soot door or doors must be provided for sweeping the chimney and connecting fluepipe where it is not intended for the chimney to be swept through the appliance.

Hearth

The hearth should be level and able to accommodate the weight of the stove and its chimney if the chimney is not independently supported. The weight of the stove is indicated in the brochure.

The stove should preferably be installed on a non-combustible hearth of a size and construction that is in accordance with the provisions of the current Building Regulations Approved Document J.

The clearance distances to combustible material beneath, surrounding or upon the hearth and walls adjacent to the hearth should comply with the guidance on the separation of combustible material given in Building Regulations Approved Document J and also in these stove instructions.

If the stove is to be installed on a combustible floor surface, it must be covered with a non-combustible material at least 12 mm thick, in accordance with Building Regulations Approved Document J, to a distance of 30 cm in front of the stove and 15 cm to each side measuring from the door of the combustion chamber.

Combustion air supply

In order for the stove to perform efficiently and safely there must be an adequate air supply into the room in which the stove is installed to provide combustion air. The provision of air supply to the stove must be in accordance with current Building Regulations Approved Document J. Special attention should be taken in newer build properties where the design air permeability is less than 5m³/h.m². Approved Document J gives more information on this. An opening window is not appropriate for this purpose.

The fitting of an external air kit direct to outside air must not be considered substitute for installing the appliance with a permanently open air vent in compliance with ventilation requirements stated in Approved Document J. Please reference ADJ for further guidance.

Connection to chimney

Stoves may have a choice of either a rear or top flue gas connector that allows connection to either a masonry chimney or a prefabricated factory made insulated metal chimney in accordance with their instructions. In some cases it may be necessary to fit an adaptor to increase the diameter of the flue to the minimum required 150 mm section of the chimney or liner. All joints in the connection between the stove and the chimney must be made gastight using fire cement and where necessary fire-proof rope infill. Means should be made for sweeping the entire length of the flue, be that through the appliance or by suitable sweeping hatch in the flue.

Commissioning and handover

Ensure all parts are fitted in accordance with the instructions.

On completion of the installation allow a suitable period of time for any fire cement and mortar to dry out, before lighting the stove. Once the stove is under fire check all seals for soundness and check that the flue is functioning correctly and that all products of combustion are vented safely to atmosphere via the chimney terminal.

On completion of the installation and commissioning ensure that the operating instructions for the stove are left with the customer. Ensure to advise the customer on the correct use of the appliance and warn them to use only the recommended fuel for the stove.

Advise the user what to do should smoke or fumes be emitted from the stove. The customer should be warned to use a fireguard to BS 8423:2002 (Replaces BS 6539) in the presence of children, aged and/or infirm persons.

IMPORTANT NOTES

General

Before lighting the stove check with the installer that the installation work and commissioning checks described above have been carried out correctly and that the chimney has been swept clean, is sound and free from any obstructions. As part of the stoves' commissioning and handover the installer should have shown you how to operate the stove correctly.

CO Alarm

Your installer should have fitted a CO alarm in the same room as the appliance. If the alarm sounds unexpectedly, follow the instructions given under "Warning Note" above.

Air Controls

Manually operated air control can be managed by adjusting the air control valve to increase/decrease the air flow to the stove.

Use of fireguard

When using the stove in situations where children, aged and/or infirm persons are present a fireguard must be used to prevent accidental contact with the stove. The fireguard should be manufactured in accordance with BS 8423:2002.

Chimney cleaning

The chimney should be swept at least twice a year. It is important that the flue connection and chimney are swept prior to lighting up after a prolonged shutdown period.

If the stove is fitted in place of an open fire then the chimney will require sweeping after a month of continuous operation. This is a precaution to ensure that any "softer" deposits left from the open fire usage have not been loosened by the higher flue temperatures generated by the closed stove.

In situations where it is not possible to sweep through the stove the installer will have provided alternative means, such as a soot door. After sweeping the chimney the stove flue outlet and the flue pipe connecting the stove to the chimney must be cleaned with a flue brush.

Periods of Prolonged Non-Use

If the stove is to be left unused for a prolonged period of time then it should be given a thorough clean to remove ash and unburned fuel residues. To enable a good flow of air through the appliance to reduce condensation and subsequent damage, leave the air controls fully open.

Extractor fan

There must not be an extractor fan fitted in the same room as the stove as this can cause the stove to emit smoke and fumes into the room.

Aerosol sprays

Do not use an aerosol spray on or near the stove when it is alight.

Use of operating tools

Always use the operating tools provided when handling parts likely to be hot when the stove is in use.

Chimney Fires

If the chimney is thoroughly and regularly swept, chimney fires should not occur. However, if a chimney fire does occur turn off the stove immediately and isolate the mains electricity supply (if applicable), and tightly close the doors of the stove. This should cause the chimney fire to go out. If the chimney fire does not go out when the above action is taken then the fire brigade should be called immediately. Do not relight the stove until the chimney and flueway have been cleaned and examined by a professional.

Permanent air vent

The stove requires a permanent and adequate air supply in order for it to operate safely and efficiently. In accordance with current Building Regulations the installer may have fitted a permanent air supply vent into the room in which the stove is installed to provide combustion air. This air vent should not under any circumstances be shut off or sealed.

POSSIBLE CAUSES OF OPERATIONAL INTERFERENCE AND HOW TO RECTIFY THEM

Poor draught in the stove after new installation

- Check the length of the chimney so that it meets NIBE's recommendations, that is a total length of at least 3.5 metres.
- Check that there is nothing in the chimney to restrict the smoke and that no nearby buildings or trees affect the winds around the chimney.
- Check the area of the chimney (applies to existing stone built chimneys), which should be 150-200 cm².

It is difficult to light the fire and the fire dies after a short time

- The wood may not be dry enough, check the wood.
- Another reason is that there may be negative pressure in the house, for example when using a kitchen extractor fan or other mechanical ventilation. Open a window near the stove before lighting the fire. Also try lighting some newspaper and holding it up inside the stove to get the draft going.
- The air supply duct from the outside may be completely or partially blocked. Disconnect the hose and try lighting the fire with combustion air from the room
- Perhaps the combustion air damper is not open.
- The smoke outlet of the stove may be blocked with soot, which can occur after sweeping. Lift the smoke baffle out and check.
- Finally go through the lighting instructions again. Perhaps the amount of kindling was too small and therefore the base embers were too weak and cold to light the next load of wood.

- The wood is damp, which causes poor combustion and generates a lot of smoke as a result.
- Too low temperature in the firebox, which causes incomplete combustion and poor draught in the chimney.
- Incorrect procedure, the door was not in the lighting position for approximately 15 minutes.

Check the moisture content of the wood, ensure that you have good base embers and go through the lighting instructions once again.

Smoke odour around the stove for periods

This can occur when wind blows down the chimney and most often occurs when the wind is from a particular direction. Another cause is the door was opened when it is burning hard.

Painted parts have become discoloured

If painted parts have discoloured it is due to an excessive temperature in the stove. The reason for the excessive temperature can be that the maximum amount of wood has been used, inappropriate fuel has been used (for example building waste, large quantities of finely chopped off cuts). The warranty does not cover damage of this type.

If a problem occurs that you cannot rectify yourself, contact the dealer or a chimney sweep.

We hope that these words of advice will help you to enjoy pleasant, economic and problem free use of your Contura stove.

WHEN THE STOVE IS NEW

When the stove is new, a particular smell may be detected, which indicates an oil coating and excess paint on the panels.

After a number of fires the smell will disappear. A particular lingering smell may occur after some use. The smell comes from the insulation in the chimney. This can be relieved by burning wood at 2.2 kg/hour for a period of 5-8 hours.

SWEEPING

Sweeping the chimney ducts and chimney connections should be carried out by a chimney sweep. The stove can be scraped down and/or swept. A soot vacuum cleaner is most appropriate however.

If a chimney fire occurs or is suspected, the combustion damper and the door must be closed. If necessary, contact the fire brigade to extinguish it. The chimney must always be inspected by a chimney sweep after a chimney fire.



- During operation, certain surfaces of the stove become very hot and can cause burn injury if touched.
- Be aware of the strong heat radiated through the hatch glass.
- Placing flammable material closer than the safe distance indicated may cause a fire.
- Smouldering can cause quick gas ignition with the risk of damage to property and personal injury.

Damper Blocker, mandatory for Smoke Control Areas

Position the damper blocker as illustrated.

Damper Blocker for C51L

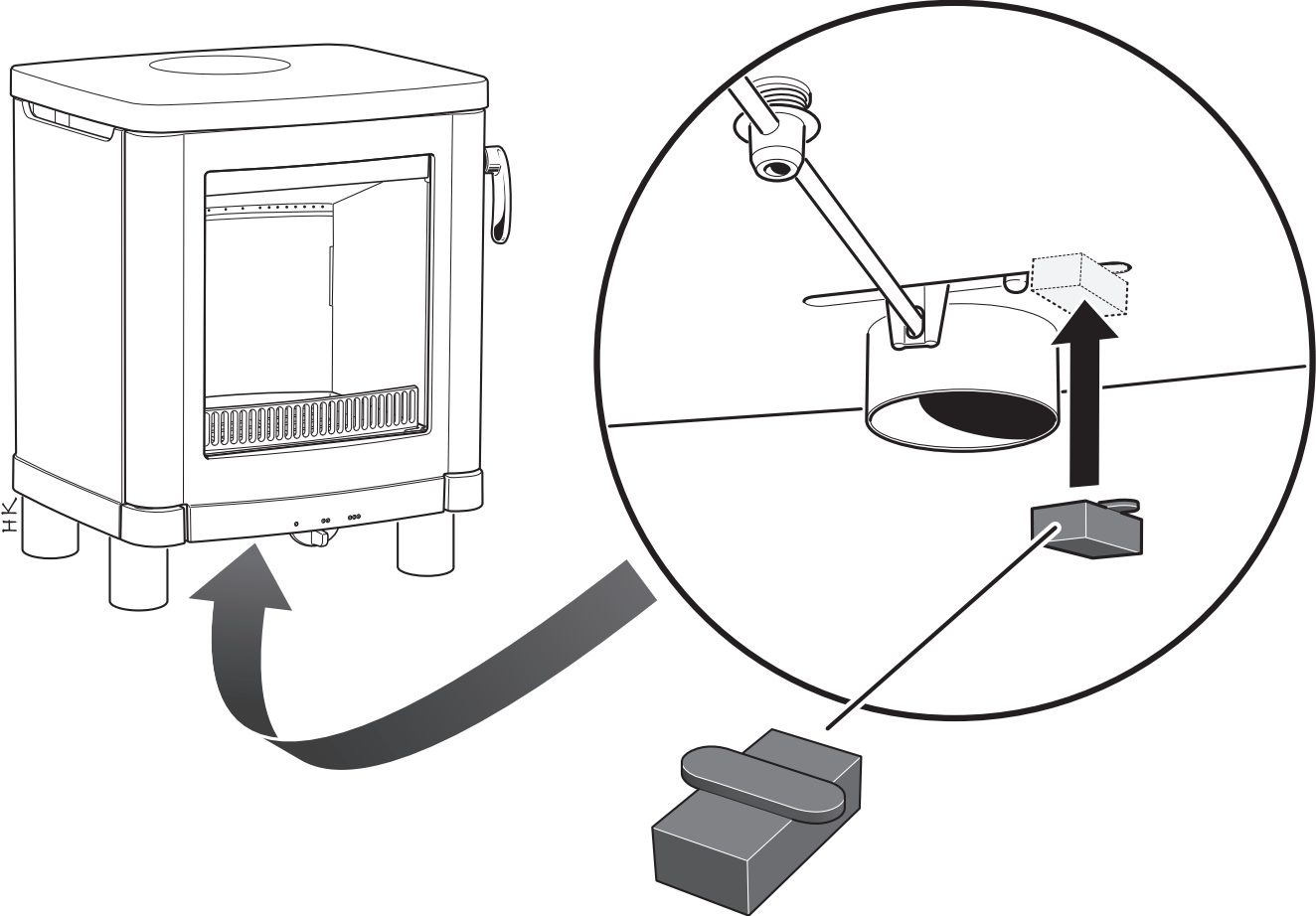

Contura

NIBE AB · Box 134 · SE-285 23 Markaryd · Sweden
contura.eu

Contura reserves the right to change colours, materials, dimensions and models at any time without special notice. Your dealer can give you the most up to date information. Stoves shown in brochures may have optional extras.

811102 IAV/BAV C51L GB-3
2023-04-06